



TG10

Condensate Vessel

Versions TG1, TG1/LA1, TG10, TK10, TK11, TK12/LA5, TK13

Special Features

- **Very corrosion-resistant**
- **Liquid level always visible**
- **Different tube connections possible**
- **Liquid level alarm possible**
- **With integrated tap**

Application

The TG/TK collection vessels are specially designed for problems in analytical technology and are used as condensate collecting vessels where automatic condensate disposal, e.g. at gas coolers, is not possible or desired, e.g. when only very small quantities of condensate are accumulated. In applications in which automatic condensate removal with a peristaltic pump is likely to result in increased condensate ingress, the collection vessel is also used as a buffer vessel. For safe operation, the collection vessels can be equipped with a liquid level alarm.

The TK11 and TK12/LA5 collection vessels are equipped with an M28 connection thread for the LA5 float switch for liquid level monitoring. The TK12/LA5 collection vessel is supplied completely with the integrated LA5 float switch with 1-m LIYY 2 x 0.14 mm² connection cable.

The manual drain valve of the TK10-TK12/LA5 collection vessels is equipped with a PVC O-ring sealed valve, which guarantees smooth operation and tightness. Three G 1/4" thread connections allow easy horizontal or vertical installation.

The horizontal connections are factory-sealed with blind plugs.

Wall-mounting profiles are an integral part of the collection vessels.

The 10 liter M&C collection vessel TK13 and TK13/LA5 with carrying handle and manual tap are made of PE. The TK13 and TK13/LA5 have three tube connections DN 4/6 for condensate inlet and ventilation.

The TK13/LA5 collection vessel is supplied with the integrated float switch LA5 with 1-m connection cable LIYY 2 x 0.14 mm² for liquid level monitoring.

The LA5 float switch is supplied as a make contact by the manufacturer. If you need a normal close contact, turn the float 180°.

Description

The M&C TG1 and TG10 collection vessels are made of industrial quality glass. This ensures high corrosion resistance and a good visibility into the vessel. A GL 25-12 clamping ring connection is available for the condensate inlet and for TG1 additionally for an optional liquid alarm sensor (not for TG10), which is supplied sealed with a blind cap.

The manual tap is equipped with a PTFE plug valve, which guarantees smooth operation and tightness. All parts in contact with the medium are made of Duran® glass and PTFE. A wall bracket is supplied as standard. The version TG1/LA 1 is supplied completely with a liquid sensor LA1S for conductive media incl. evaluation electronics LA1.1 in wall-mounted version. Special connection adapters for connecting tubes to GL connections are optionally available.

The M&C collection vessels TK10-TK12/LA5 are made of transparent PVC. High corrosion resistance and insight into the vessel are ensured. The TK10-TK12/LA5 has a G 3/8" connection for the condensate inlet. For possible special functions, the TK10 collecting vessel also has two G 1/4" connections which are closed with blind plugs. The TK12 collecting vessel has one G 1/4" connection for ventilation purposes.

Condensate vessel TG1

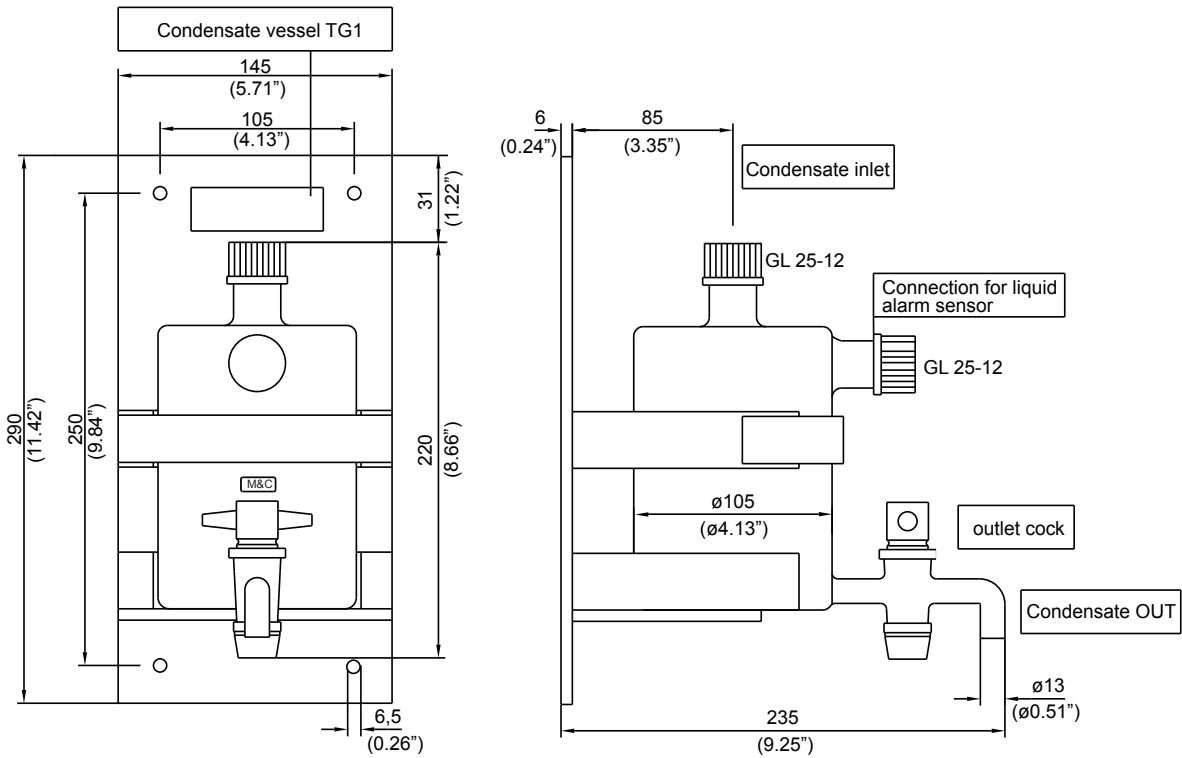

Condensate vessel TK10

Condensate vessel TK11, TK12/LA5

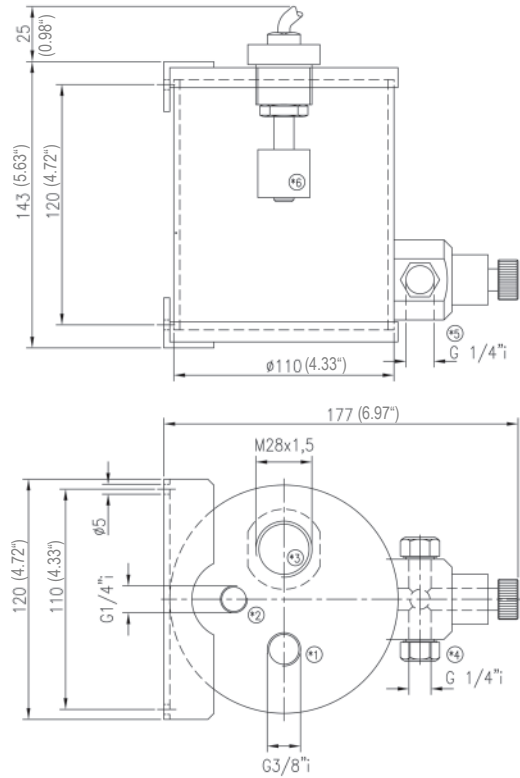
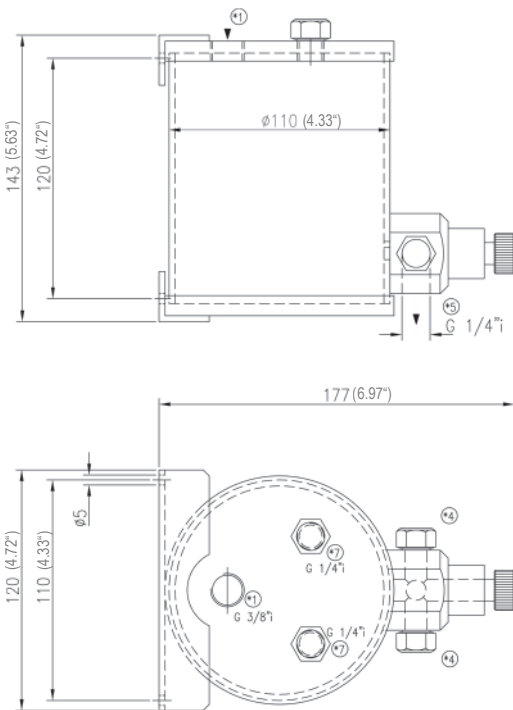

Dimensions in mm

- *1: Condensate IN
- *2: Ventilation
- *3: Connection thread for liquid level alarm LA5
- *4: Condensate OUT (lateral)
- *5: Condensate OUT (downwards)
- *6: Liquid level alarm LA5
- *7: Two additional connections, which are sealed with blind plugs

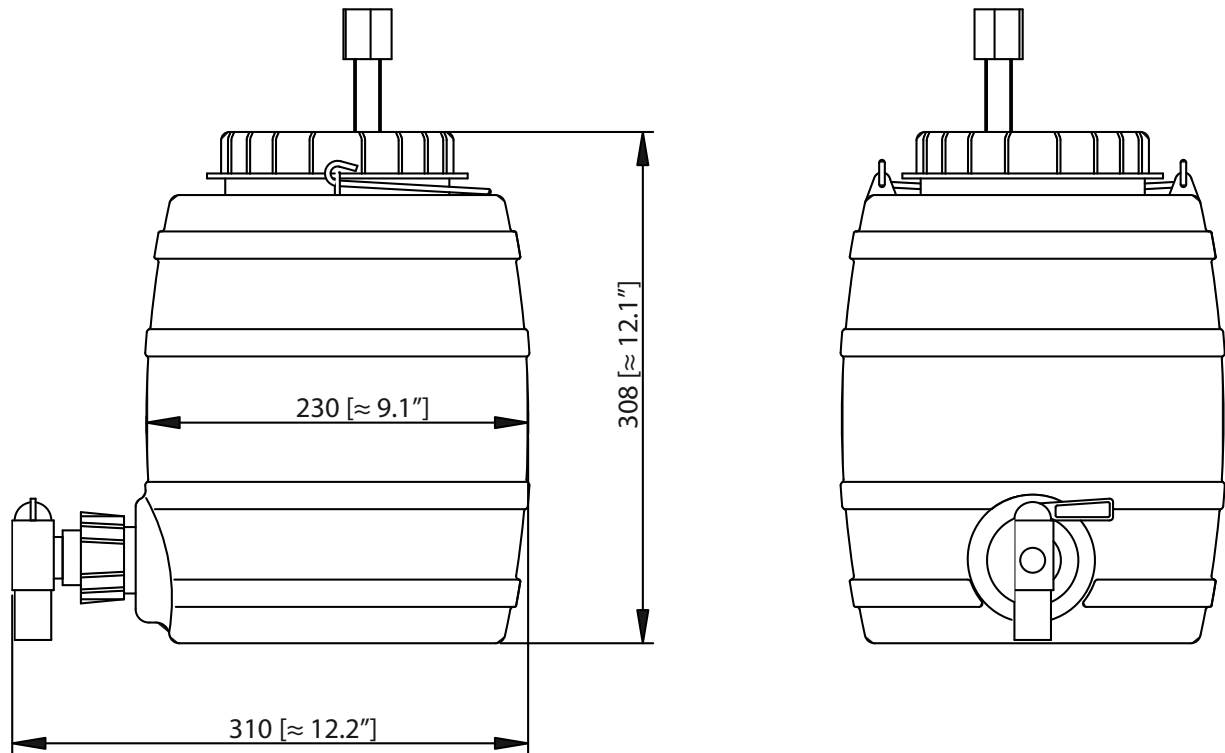

Technical Data

Condensate vessel	TG1	TG1/LA1	TG10
Part No.	09K4000	09K4100	09K4050
Contents	Approx. 1 liter [≈ 0.3 gal]		
Operating pressure at 20 °C [68 °F]	0.2 to 2 bar abs.		
Sample temperature	0 to +80 °C [32 to 176 °F]		
Ambient temperature	0 to +55 °C [32 to 131 °F]		
Storage temperature	-15 to +65 °C [5 to 149 °F]		
Material of sample-contacting parts	Duran® glass, PTFE		
Dimensions (W x H x D)	145 x 290 x 235 mm [≈ 5.7" x 11.4" x 9.3"]		
Connections	1 x GL 25-12, 1 x GL 25, 1 x 13 mm nipple	2 x GL 25-12, 1 x 13 mm nipple	1 x GL 25-12, 1 x 13 mm nipple
Weight	1 kg [≈ 2.2 lbs]	1.2 kg [≈ 2.7 lbs]	1 kg [≈ 2.2 lbs]
With liquid level alarm unit	NO (option)	YES	NO
Power supply		115/230 V 50/60 Hz 2 VA	

Condensate vessel	TK10	TK11	TK12/LA5	TK13	TK13/LA5
Part No.	09K4250	09K4200	09K4300	09K4310	09K4320
Contents approx.	1 liter [≈ 0.3 gal]			10 liters [≈ 2.6 gal]	
Operating pressure at 20 °C [68 °F]	0.2 to 2 bar abs.			Atmospheric	
Sample temperature	0 to +50 °C [32 to 122 °F]				
Ambient temperature	0 to +55 °C [32 to 131 °F]				
Storage temperature	-15 to +65 °C [5 to 149 °F]				
Connection condensate IN	1 x G 3/8" i, 2 x G 1/4" i	1 x G 3/8" i, 1 x M 28 x 1.5 i	1 x G 3/8" i, 1 x M 28 x 1.5 i, 1 x G1/4" i (ventilation)	3 x DN 4/6	2 x DN 4/6
Connection condensate OUT	3 x G 1/4" i			Plug valve opening ø 11.5	
Dimensions	See drawing			ø 235 mm [ø ≈ 9.3"], height 310 mm [≈ 12.2"]	
Weight	0.5 kg [≈ 1.1 lbs]		0.6 kg [≈ 1.3 lbs]	1 kg [≈ 2.2 lbs]	
Sample-contacting parts	PVC, FKM	PVC, FKM	PVC, FKM	PE, rubber, PVDF	
With liquid level alarm	NO	NO (option)	YES	NO	YES
Contact rating				48 V 0.5 A 10 W	

Duran® is a registered trademark for borosilicate glass by DWK Life Sciences GmbH, Germany.