



SP180-H

Gas Sample Probe Series SP®

Electrically heated, compact version with weather protection cover and test gas connection as standard

SP180-H

SP180-H EX2 T2, SP180-H EX2 T3, SP180-H EX2 T4

SP180-H EX1 T2, SP180-H EX1 T3, SP180-H EX1 T4

Special Features

- **3 EX2 versions: T2/T3/T4 with Ex certification according to ATEX, suitable for use in Ex zone 2**
- **3 EX1 versions: T2/T3/T4 with Ex certification according to ATEX, suitable for use in Ex zone 1**
- **IECEX for zone 1**
- **Sampling of dust-loaded process gases**
- **Small volume, fast response time**
- **Self-regulating electrical heating**
- **Alarm contact for low temperature**
- **With test gas connection according to EN 14181 (test gas feeding via filter element)**
- **Easy mounting and maintenance**
- **Sample tube and pre-filter optional**

Application

The M&C gas sample probe versions SP180-H, SP180-H EX1 T2/T3/T4 and SP180-H EX2 T2/T3/T4 are used for continuous gas sampling. The compact design requires only limited space. The gas sample probe is equipped with a new weather protection cover and thus also suitable for outdoor mounting.

The gas sample probes SP180-H, SP180-H EX1 T2/T3/T4 and SP180-H EX2 T2/T3/T4 have a calibration gas connection as standard according to EN 14181 (regulation for calibration of emission monitoring systems) that enables calibration gas feeding via the filter element of the gas sample probe.

Description

The design of the M&C probe versions SP180-H, SP180-H EX1 T2/T3/T4, SP180-H EX2 T2/T3/T4 guarantees simple mounting, reliable operation and trouble-free maintenance.

The Ex versions SP180-H EX2 T2, SP180-H EX2 T3 and SP180-H EX2 T4 are suitable for usage in Ex zone 2. The alarm contact for low temperature corresponds to the temperature classes of the Ex versions.

Changing the external filter element needs no tools and no disassembling of the sample line. To replace the filter element, the complete filter assembly is removed out of the filter chamber. Simple inspection of the sealing elements, easy cleaning of the filter chamber and the possibility of pushing through the sample tube without removing the probe are just a few of the many advantages offered by the M&C probe.

The Ex versions SP180-H EX1 T2, SP180-H EX1 T3 and SP180-H EX1 T4 are suitable for usage in Ex zone 1. The alarm contact for low temperature corresponds to the temperature classes of the Ex versions.

The ceramic deep-acting filter element with a porosity of 2 µm is located in the heated filter housing out of stainless steel. More filter element materials are available as options. The compact design and the new all-round heat insulation and weather protection ensure an optimized heat distribution as well as safe operation in the filter or probe flange area without dew point underrun.

The stainless steel sample tube SP210/SS (option) can be screwed into the mounting flange. The maximum operating temperature of the sample tube out of stainless steel is 600 °C [1112 °F].

The gas sample probe can be heated up to 180 °C [356 °F] with special self-regulating heating elements within a range from 110 V to 240 V without switching.

The gas sample probe SP180-H, which is not ATEX certified, can be used in combination with the heated double-jacket sample tubes SP30-H or SP35-H (see data sheet "Electrically Heated Sample Probe Tube Series SP®, Versions SP30-H, SP30-H1.1-V, SP35-H") for long and cold mounting stubs or for process temperatures below the dew point.

Neither a temperature controller nor a temperature limitation is necessary. The separate thermostitch of the SP180-H enables a low temperature monitoring (< 160 °C [320 °F], NO). For electrical connection, a junction box with terminals is mounted.

To solve specific sampling problems, you can find more filter elements, sample tubes and pre-filters in our wide range of M&C probe accessories (see data sheets for sample tubes with G 3/4" connection thread and pre-filters with G 3/4" connection, with flange connection and with tube connection).

Series SP®	SP180-H	SP180-H EX2 T2	SP180-H EX2 T3	SP180-H EX2 T4
Part No.	02S1800	02S1890	02S1885	02S1880
Protective cover	Yes			
Outdoor mounting	Yes			
Sample temperature	Max. 600 °C [1112 °F]*			
Sample pressure	0.4 to 6 bar abs.			
Ambient temperature	(-40 °C) -25 to +80 °C** [(-40 °F) -13 to +176 °F]**	-20 to +80 °C [-4 to +176 °F]	-20 to +80 °C [-4 to +176 °F]	-20 to +80 °C [-4 to +176 °F]
Dust load	Max. 1 g/m ³			
Filter chamber volume	70 ml			
Filter element	Type S-2K, filter porosity 2 µm, ceramic (others on request)			
Probe heating	180 [356 °F] self-regulating	150 to 180 °C [302 to 356 °F] self-regulating	120 to 160 °C [248 to 320 °F] self-regulating	90 to 120 °C [194 to 248 °F] self-regulating
Ready for operation	After 2 hours			
Low temperature alarm contact, alarm point	< 160 °C [320 °F], NO	< 90 °C [194 °F], NO	< 90 °C [194 °F], NO	< 90 °C [194 °F], NO
Low temperature alarm contact, contact rating	250 V - 3 A AC, 30 V - 3 A DC	250 V - 1.5 A AC 0.5 A DC		
Connection sample gas outlet	1/4" NPT inside with Swagelok® tube connector ø 6 x 1 mm (DN 4/6)			
Connection calibration gas	Swagelok® tube connector ø 6 x 1 mm (DN 4/6)			
Power supply	110 up to 240 V 50/60 Hz, rated current 3.5 A			
Power consumption	Typically: 100 VA, (fuse 6 A)			
Electrical connection	Terminals max. 2.5 mm ² , 1 x M20, 1 x M16 cable glands			
Mounting flange	DN 65 PN 6, B stainless steel 316Ti			
Material of sample contacting parts	Stainless steel 316/316Ti, FKM, ceramic			
Degree of protection/Electrical equipment standard	IP54 EN 60529/EN 61010			
Ex Certification	None	II 3G Ex ec mc IIC T2 Gc	II 3G Ex ec mc IIC T3 Gc	II 3G Ex ec mc IIC T4 Gc
Dimensions (W x H x D)	230 x 280 x 225 mm [≈ 9.1" x 11.0" x 8.9"]			
Weight	Approx. 7.5 kg [≈ 16.5 lbs]			
Flow	Max. 500 NI/h			
Options				
02S9200	Sample tube out of stainless steel 316Ti type SP210/SS, connection G 3/4" o, ø 10/12, length: 1 m [≈ 3.3 ft]*, incl. flange gasket.			

* Standard, other versions on request.

** The safe operation of the heating elements at ambient temperatures of up to -40 °C [-40 °F] needs to be guaranteed. Turning off the heating elements at ambient temperatures below -25 °C [-13 °F] can destroy the sealing materials of the gas sample probe.

Swagelok® is a registered trademark for tube fittings by Swagelok Company, USA.

Please note: NI/h and NI/min refer to the German standard DIN 1343 and are based on these standard conditions: 0 °C [32 °F], 1013 mbar.

ΔP and T90 at a flow rate of:	100	200	500	NI/h
ΔP pressure loss with new filter element S-2K	4	7	15	mbar
T90 time with sample tube SP210/SS	4.0	2.5	< 1.0	sec.

Dimensions

SP180-H and EX versions

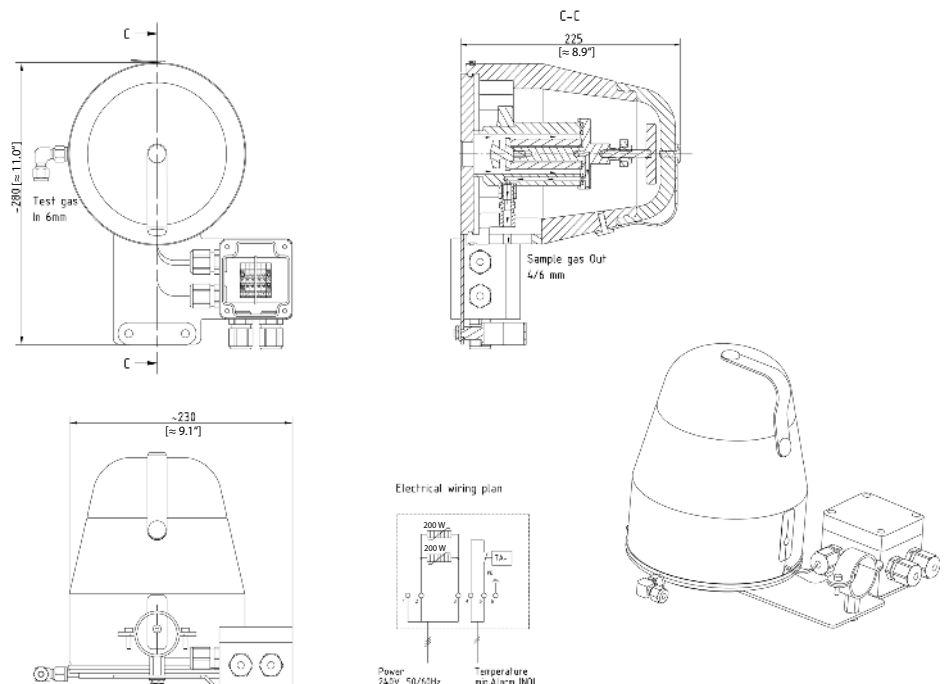

Dimensions in mm
[Inches]



SP180-H EX1

Technical Data SP180-H EX1

Series SP®	SP180-H EX1 T2	SP180-H EX1 T3	SP180-H-EX1 T4
Part No.	02S1874	02S1872	02S1870
Protective cover	Yes		
Outdoor mounting	Yes		
Sample temperature	Max. 600 °C [1112 °F]*		
Sample pressure	0.4 to 6 bar abs.		
Ambient temperature	-20 to +80 °C [-4 to +176 °F]	-20 to +80 °C [-4 to +176 °F]	-20 to +80 °C [-4 to +176 °F]
Dust load	Max. 1 g/m ³		
Filter chamber volume	70 ml		
Filter element	Type S-2K, filter porosity: 2 µm, ceramic (others on request)		
Probe heating	+150 to +180 °C [+302 to +356 °F] self-regulating	+120 to +160 °C [+248 to +320 °F] self-regulating	+90 to +120 °C [+194 to +248 °F] self-regulating
Ready for operation	After 2 hours		
Low temperature alarm contact, alarm point	< 90 °C [194 °F], NO	< 90 °C [194 °F], NO	< 90 °C [194 °F], NO
Low temperature alarm contact, contact rating	250 V - 1.5 A AC 0.5 A DC		
Connection sample outlet	1/4" NPT inside with Swagelok® tube connector ø 6 x 1 mm (DN 4/6)		
Connection calibration gas	Swagelok® tube connector ø 6 x 1 mm (DN 4/6)		
Power supply	110 up to 240 V 50 / 60 Hz, rated current 3.5 A		
Power consumption	Typically: 100 VA, (fuse 6 A)		
Electrical connection	Terminals max. 2.5 mm ² , 1 x M20, 1 x M16 cable glands		
Mounting flange	DN 65 PN 6, B stainless steel 316Ti		
Material of sample contacting parts	Stainless steel 316/316Ti, FKM, ceramic		
Degree of protection/electrical equipment standard	IP54 EN 60529/EN 61010		
Ex Certification	II 2G Ex eb mb IIC T2 Gb	II 2 G Ex eb mb IIC T3 Gb	II 2G Ex eb mb IIC T4 Gb
	EXAM BVS 18 ATEX E 043		
	IECEX BVS 18.0034		
Dimensions (W x H x D)	230 x 280 x 225 mm [≈ 9.1" x 11.0" x 8.9"]		
Weight	Approx. 7.5 kg [≈ 16.5 lbs]		
Flow	Max. 500 NI/h		
Options			
02S9200	Sample tube out of stainless steel 316Ti type SP210/SS, connection: G 3/4" o, ø 10/12, length: 1 m [≈ 3.3 ft]*, incl. flange gasket		

*Standard, other versions on request.

Swagelok® is a registered trademark for tube fittings by Swagelok Company, USA.

Please note: NI/h and NI/min refer to the German standard DIN 1343 and are based on these standard conditions: 0 °C [32 °F], 1013 mbar.

ΔP and T90 at a flow rate of:	100	200	500	NI/h
ΔP pressure loss with new filter element S-2K	4	7	15	mbar
T90 time with sample tube SP210/SS	4.0	2.5	< 1.0	sec.