



CSS-VC1

Gas Conditioning Unit Series CSS®

Version CSS-VC1 for max. 1 x 250 NI/h gas flow rate, version CSS-VC2 for max. 2 x 150 NI/h gas flow rate, for 19"-rack or wall-mounting or portable in transport case

Special Features

- **Compact high-performance design with compressor cooler**
- **Individually configurable**
- **Completely pre-installed**
- **Multifunctional control unit (TCU) with warning and fault indication in plain text**
- **One or two gas paths**
- **19"-rack/wall-mounting/transport case/trolley system**
- **Adjustable dew point outlet: +2 to +7 °C [+ 35.6 to + 44.6 °F]**
- **Water vapor dew point input up to 80 °C [176 °F]**
- **Dew point stability ± 0.1 °C [± 0.18 °F]**
- **Ready for operation in 10 minutes**
- **Operating hours counter**
- **History memory**

Application

The CSS-VC1 und CSS-VC2 units provide completely pre-installed compact high-performance sample gas conditioning systems for continuous use. Due to the multifunctional expandable control unit TCU and a wide variety of additional options, the sample gas conditioning units can excellently be adapted to the most diverse requirements of gas analysis technology and therefore perform the tasks of complete analyzing systems.

The compact design only requires little space. The CSS-VC1/VC2 units are ready for use in just a few minutes. This makes the time-consuming procurement of individual components and small parts as well as their assembly superfluous. A portable version in a transport case is also possible.

Description

All components of the gas conditioning units are mounted in a robust, compact sheet steel case for wall- or 19"-rack mounting. The ventilation grids in the sidewalls ensure that the equipment is sufficiently ventilated.

Filter, flow meter and peristaltic pumps are located in the front panel and thus ensure easy maintenance. A removable cover and a foldable front plate also allow a quick and easy inspection and maintenance of all other installed components, in particular a simple replacement of heat exchangers.

The compressor gas cooler is equipped with one or two heat exchangers of Duran® glass, stainless steel SS 316Ti or PVDF. Peristaltic pumps type SR25.2 are used for continuous condensate removal or are also used as dosing pumps. The current cooler temperature is displayed on the multifunctional TCU control unit installed at the front. The setpoint temperature of the cooler can be set via keys. In case of warnings or malfunctions, plain text information is shown on the display and additionally indicated by LEDs (cooler within the setpoint range: green LED, flow alarm

(option): yellow LED, temperature ±3 °C from setpoint and humidity alarm (option): red LED).

The fine filter downstream of the cooler (different filter types possible) ensures the necessary separation of solids. The condition of the filter is visible from the outside. To protect the downstream analyzers against liquid inrush and to increase the operating reliability of the whole system - depending on the selected type of filter - a suitable liquid alarm sensor is possible or already integrated into the filter.

A collective alarm message or, on request, individual alarm messages including mA output for the cooler temperature connected to output terminals are available. Via potential-free contacts for the collective alarm or the individual alarms (cooler temperature, flow rate, liquid in the system), an alarm signal is given and the sample gas pump, if present, is switched off.

Integrable sample gas pump is available in 3 pump capacities N3/5/9 KPE. The FM40 flow meter installed at the sample gas outlet with a measuring range adapted to the pump capacity can be equipped with an FA-20mo flow sensor for flow monitoring. In addition, a second sample gas outlet or bypass, also optionally with flow meter and flow monitoring, can be set up for each sample gas path.

In the event of an aerosol problem, a liquid particle filter can be installed downstream the flow meter in the sample gas outlet.

Two further temperature controllers are available as extension modules for the TCU control unit, e.g. for controlling heated lines or gas sample probes. In addition, external sample gas pumps can be switched and gas sample probes can be individually back-purged.

Example configuration CSS-VC1

- 1 Gas cooler series **ECM-1**
- 2 Option universal filter or front panel filter **FPF-0,1GF**, 0.1 µm, optional with liquid alarm **LA** or front panel filter **FPF+**, optional with integrated liquid alarm
- 3 Option 3 or 5-way-ball valve **3L/PV** or **5L/PV**
- 4 Option sample gas pump N3/5/9KPE
- 5 Option peristaltic pump **SR25.2**
- 6 Option flow meter **FM40** with flow alarm
- 7 Option flow meter **FM40**
- 8 Option liquid particle filter **CLF-5/W** or **CLF-T(SS)**

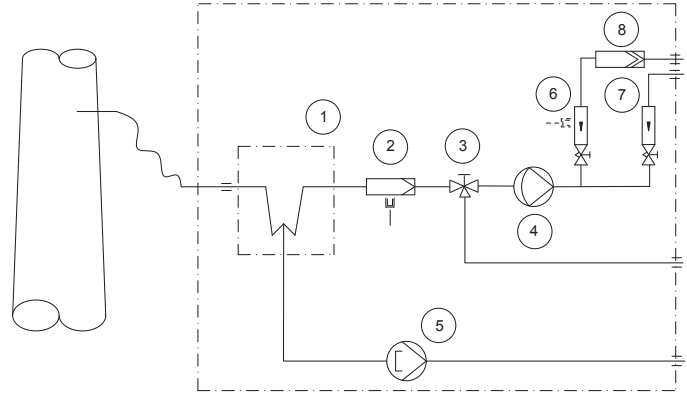

Example configuration CSS-VC2

- 1 Gas cooler series **ECM-2**
- 2 Option universal filter or front panel filter **FPF-0,1GF**, 0.1 µm, optional with liquid alarm sensor **LA** or front panel filter **FPF-2-0,3GF**, 0.3 µm, with integrated liquid alarm sensor
- 3 Option 3 or 5-way-ball valve **3L/PV** or **5L/PV**
- 4 Option sample gas pump **N3/5/9KPE**
- 5 Option peristaltic pump **SR25.2**
- 6 Option flow meter **FM40** with flow alarm
- 7 Option flow meter **FM40**
- 8 Option liquid particle filter **CLF-5/W** or **CLF-T(SS)**

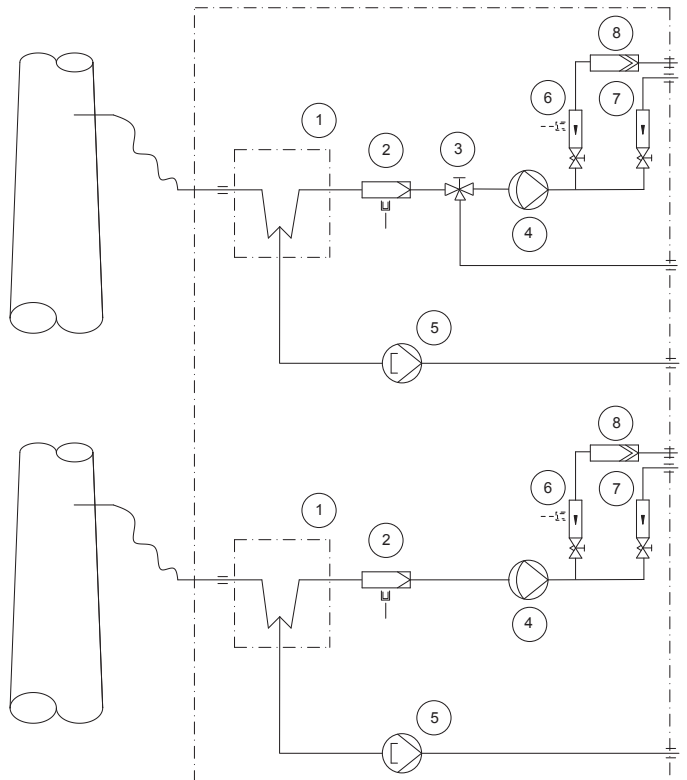

Dimensions CSS-VC1/VC2

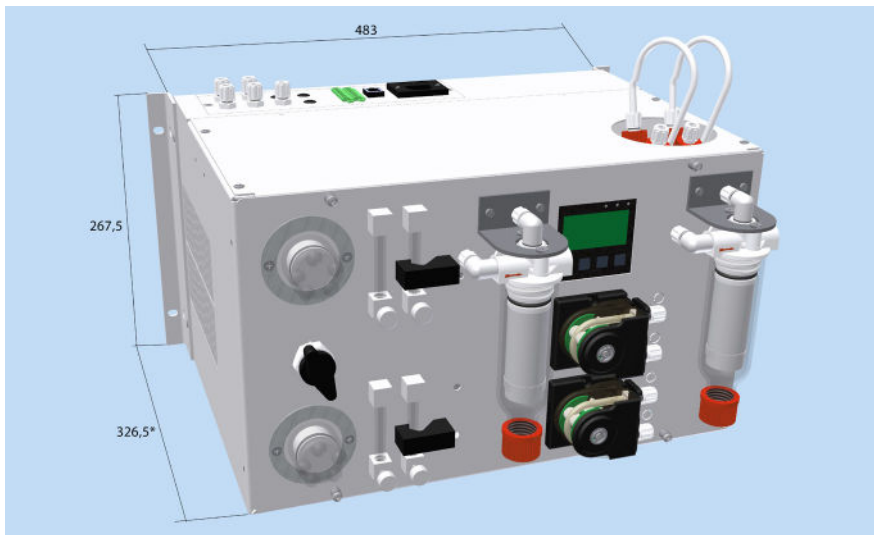

Dimensions in mm
 * 301.5 without wall-mounting brackets

Gas Conditioning Unit Series CSS®	Version CSS-VC1	Version CSS-VC2
Part No. 230 V/50 Hz	01G6050	01G6055
Part No. 115 V/50-60 Hz	01G6050a	01G6055a
Sample outlet dew point	Range of adjustment: +2 to +7 °C [35.6 to 44.6 °F], factory setting: +5 °C [41 °]	
Dew point stability	At constant conditions < ±0.1 °C [< ±0.18 °F]	
Sample inlet temperature*	Max. 180 °C [356 °F]	
Sample inlet dew point*	Max. 80 °C [176 °F]	
Gas flow rate*	Max. 250 NI/h	Max. 2 x 150 NI/h
Ambient temperature*	+10 up to +40 °C [41 up to 104 °F]	
Storage temperature	-25 up to +65 °C [-13 up to 149 °F]	
Pressure	0.7 bar up to 1.4 bar abs.	
Total cooling capacity*	Max. 144 kJ/h	
Number of gas inlets	1	2
Number of gas outlets	1	2
Condensate outlet	1	2
Medium connections	Tube connection DN 4/6	
Material of sample-contacting parts	Heat exchanger: Duran® glass, PVDF or stainless steel 1.4571 Tubing and fittings: PTFE, PVDF Universal filter FP-2T-D: PVDF, FKM, glass, PTFE Front-panel filter FPF-0,1GF: PVDF, glass, FKM Front-panel filter FPF+: PVDF, glass, FKM Peristaltic pump SR25.2: PVDF, Novoprene Liquid particle filter CLF-5/W: PVDF, glass, FKM, PTFE Sample gas pumps N3/5/9: PVDF, PTFE, FKM Flow meter FM40: PVDF, glass, FKM, Hastelloy® C-4 Ball valve 3L/PV and 5L/PV: PVDF, FKM	
Ready for operation	Approx. 10 min.	
Power supply	230 V/50-60 Hz ±10 % or 115 V/50-60 Hz ±10 %**	
Power consumption	Max. 220 VA + max. 300 VA for the sample gas pumps	
Fuse protection	4 A t, 5 x 20 mm	
Electrical connection	Cold appliance plug with 2 m [≈ 6.6 ft] cable	
Case protection	IP20 EN 60529	
Housing protection	Sheet steel case for 19"- or wall-mounting, lacquered RAL 7032	
Equipment dimensions (H x W x D)	267.5 x 483 x 301.5 mm [≈ 10.5" x 29" x 11.9"] (portable version : 355 x 515 x 395 mm [≈ 14" x 20.3" x 15.5"])	
Electrical equipment standard	EN 61010	
Weight	Approx. 22 kg [≈ 48.5 lbs]	

* Maximum values in the technical data must be rated in consideration of the total cooling power at 25 °C [77 °F] and an outlet dew point of 5 °C [41 °F].

** 115 V/50 Hz sample gas pump also possible.

PVDF: Polyvinylidenfluoride; PVC: Polyvinylchloride; FKM: Fluroelastomer = Viton®; PPH: Polypropylene type homopolymer; PTFE: Polytetrafluoethylene
Viton®, Duran® and Hastelloy®C-4 are registered trademarks.

Please note: NI/h and NI/min refer to the German standard DIN 1343 and are based on these standard conditions: 0 °C [32 °F], 1013 mbar.

Options

Description	Part No.
Heat Exchangers and Housing Version	
Extra charge for gas connections directly at one heat exchanger	01G6062
Extra charge for heat exchanger ECM-1 out of glass for CSS-VC1, sample gas connections at the Jet-Stream heat exchanger	93K0140
Extra charge for heat exchanger ECM-1 out of stainless steel SS316Ti for CSS-VC1, sample gas connections at the Jet-Stream heat exchanger	93K0160
Extra charge for heat exchanger ECM-1 out of PVDF for CSS-VC1, sample gas connections at the Jet-Stream heat exchanger	93K0170
Extra charge for gas connections directly at two heat exchangers	01G6063
Extra charge for heat exchanger ECM-2 out of glass for CSS-VC2, sample gas connections at the heat exchanger	97K0100
Extra charge for heat exchanger ECM-2 out of stainless steel SS 316Ti for CSS-VC2, sample gas connections at the heat exchanger	97K0115
Extra charge for heat exchanger ECM-2 out of PVDF for CSS-VC2, sample gas connections at the heat exchanger	97K0110
Extra charge for gas connections of one heat exchanger in the joint plate for e.g. 19" mounting	01G6060
Extra charge for heat exchanger ECM-1 90° out of glass for CSS-VC1, sample gas connections in the joint plate for e.g. 19" mounting	93K0150
Extra charge for heat exchanger ECM-1 out of PVDF for CSS-VC1, sample gas connections in the joint plate for e.g. 19" mounting	93K0170
Extra charge for gas connections of two heat exchangers in the joint plate for e.g. 19" mounting	01G6061
Extra charge for Jet-Stream heat exchanger ECM-2 90° out of glass for CSS-VC1, sample gas connections in the joint plate, e.g. 19" mounting	97K0150
Extra charge for Jet-Stream heat exchanger ECM-2 out of PVDF for CSS-VC1, sample gas connections in the joint plate, e.g. 19" mounting	97K0110
Peristaltic pumps for condensate removal (max. 2 pcs.)	
Extra charge for mounting a peristaltic pump SR25.2 for condensate removal, completely flexible tubed (one per gas path necessary)	01G6140
Filters (max. 2 pcs. front-panel filters and 2 pcs. universal filters or aerosol filters) and liquid alarm sensor	
Extra charge for mounting front-panel filter FPF-0,1GF	04F1000

Description	Part No.
Extra charge for flow chamber LS/LA2 with flow alarm sensor at front panel filter FPF-0,1GF	03E3010
Extra charge for mounting a front panel filter FPF+	04F2100
Extra charge for a filter element for FPF+ (depending on filter element)	As requested
Extra charge for liquid alarm sensor LA3 integrated in FPF+	03E1300
Extra charge for universal filter (see data sheet 7.1)/aerosol filter CLF... (see data sheets 7.7 and 7.8)	As requested
Extra charge for mounting an universal filter/aerosol filter CLF on front plate (max. 2 pcs.)	01G6075
Extra charge for liquid alarm sensor LA1S for universal filter F.-.-D	03E3001
Ball valves for test gas feeding (max. 1 pc.)	
Extra charge for mounting a 3-way ball valve 3L/PV	01G9046
Extra charge for mounting a 5-way ball valve 5L/PV	01G9045
Sample gas pumps (max. 2 pcs.) (only with electronic controller 01G6175)	
Extra charge for preparing the installation of sample gas pumps N...KPE	01G6070
Extra charge for mounting the sample gas pump N3KPE	01G6125
Extra charge for mounting the sample gas pump N5KPE	01G6130
Extra charge for mounting the sample gas pump N9KPE	01G6135
Flow meter (max. 4 pcs. in total) and flow alarm (max. 2 pcs.)	
Extra charge for mounting a float-type flow meter FM40 7-70 NI/h in sample gas outlet	09F4000
Extra charge for mounting a float-type flow meter FM40 15-150 NI/h in sample gas outlet	09F4005
Extra charge for mounting a float-type flow meter FM40 25-250 NI/h in sample gas outlet	09F4010
Extra charge for mounting a float-type flow meter FM40 50-500 NI/h in sample gas outlet	09F4015
Extra charge for forked flow alarm sensor FA-20mo	02E3500
Extra charge for bypass flow meter FM40 7-70 NI/h with needle valve and sample gas outlet	01G6200
Extra charge for bypass flow meter FM40 15-150 NI/h with needle valve and sample gas outlet	01G6210
Extra charge for bypass flow meter FM40 25-250 NI/h with needle valve and sample gas outlet	01G6220
Extra charge for bypass flow meter FM40 50-500 NI/h with needle valve and sample gas outlet	01G6230
Electronic controllers	
Extra charge for electronic controller with collective status alarm	01G6170
Extra charge for single alarm messages (temperature, flow, liquid in the system) inclusive mA output for cooler temperature for external temperature display, factory setting: 4-20 mA (0 to 50 °C [32 to 122 °F]), on request 0-20 mA available	01G6175
External additional modules (only with electronic controller 01G6175)	
Extra charge for communication module (only necessary once for all extension modules of the TCU)	01B8620
Extra charge for temperature controller module (2 additional temperature controllers in TCU with 4 relays for high or low temperature monitoring) for control of solid state relays For controller parameterization, please specify in the order which M&C devices should be controlled (type of gas sample probe(s) as well as type and length of heated sample line(s)).	01B8640
Extra charge for status module for collective alarm message via 1 changeover contact relay and 1 solid state relay for switching of external sample gas pumps	01B8630
Extra charge for blowback module for programmed control of solenoid valves for blowback of gas sample probes with status monitoring (measuring/blowback), monitoring of the blowback pressure and control of the sample gas pumps (on/off)	01B8650
Extra charge for M&C bus for external modules	01G6180
Carrying case (only for 19"-version)	
Extra charge for carrying case for portable gas conditioning	01G6250
Extra charge for trolley system	90G0160
Temperature controller for portable version (only with electronic controller 01G6175)	
Extra charge for temperature controller for max. 10 m heated sample line, 230 V with PT100, with solid state relays and 7-pole plug	01G6190
Anti-kink protection adapter for portable gas conditioning	
Extra charge for anti-kink protection for heated sample line DN 4/6	01G9060
Extra charge for anti-kink protection for heated sample line DN 6/8	01G9061

Order example:

1x 01G6050 + 1 x 01G6060 + 1 x 93K0150 + 1 x 01G6140 + 1x 04F2100 + 1 x 90F0002 + 1 x 03E1300 + 1 x 03F3005 + 1 x 01G6075 + 1 x 01G6070 + 1 x 01G6130 + 1 x 09F4005 + 1 x 02E3500 + 1 x 01G6210 + 1 x 01G6175 + 1 x 01G9160 =

CSS-VC1, 230 V, with heat exchanger out of glass, sample gas connections in the joint plate, built-in peristaltic pump SR25.2, built-in front panel filter FPF+2T with integrated liquid alarm sensor LA3, aerosol filter CLF-5/W mounted on front panel, built-in sample gas pump N5KPE, flow meter FM40 15-150 NI/h and flow alarm sensor FA-20mo in the sample outlet, flow meter FM40 15-150 NI/h in the bypass, single alarm messages and mA outlet for external cooling temperature indication, temperature controller module TCU

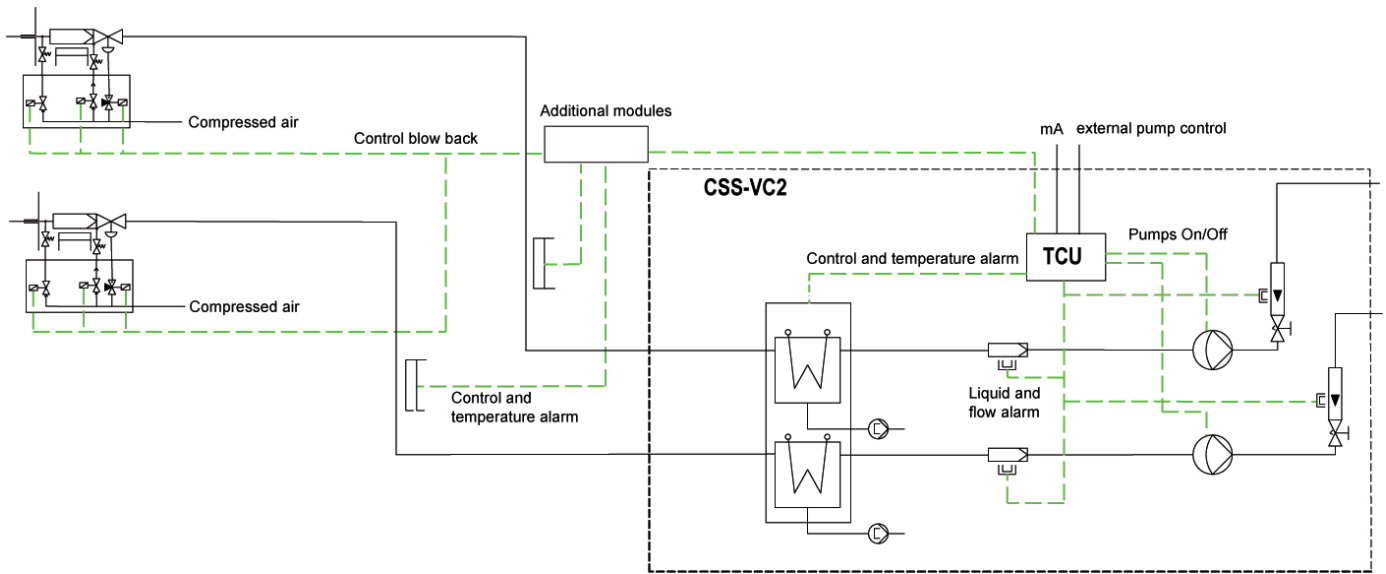

CSS-VC with trolley system

