



JCT
Analysentechnik

JCM-300 Peltier Sample Gas Cooler



Gas Sampling
Probes

Heated Sample
Lines

Sample Gas Coolers

Condensate
Treatment

Accessories

Gas Conditioning
System

Sample Gas
Converters

APPLICATION

- Extractive gas analysis
- Emission and process monitoring
- Continuous drying of sample gas to a precise low and constant outlet dew point
- Minimises water vapour cross sensitivities and volumetric errors

BENEFITS

- Very powerful compact complete unit with condensate removal and monitoring
- High flow rates of up to 250 NI/h
- Very low wash out ratios even at high water vapour concentrations in the sample gas
- High inlet dew points possible
- Reliable condensate separation
- Extremely precise long-term stable dew point even under varying loads
- Maximum operational safety
- Low maintenance operation
- Easy to maintain design

FEATURES

- New modular designed compact construction
- New heat exchanger JHEX-4 in different materials
- Intelligent digital control electronic
- Applicable up to high ambient temperatures
- Integrated condensate pump as option
- Integrated condensate monitoring as option
- Status contact for temperature thresholds as well as for condensate alarm
- Visual alerting via LEDs
- Self monitoring with deactivation of the external sample pump in case of alarm

TECHNICAL DATA

Model	JCM-300
Performance	standard
Cooling principle	Peltier cooling
Number of gas paths	1
Number of Peltier elements	1
Integrated condensate pump	option
Integrated condensate monitoring	option

Operation

Gas flow per gas path*	max. 250 NI/hr
Gas inlet temperature*	max. 140 °C; SS heat exchanger: max. 180 °C
Gas inlet dew point*	max. 80°C
Gas outlet dew point	5 °C (factory default); adjustable from 0,5 °C to 7,5 °C
Dew point stability (for constant inlet conditions)	±0,1 K
Ambient temperature	5° to 45 °C
Cooling capacity total	max. 15 W
Operating pressure with condensate pump	0,2 to 2,2 bara
Max. operating pressure without condensate pump	4,0 bara; SS heat exchanger: max. 19 bara
Ready for operation	< 30 min
Pressure drop at max. flow rate	3 mbar

Construction

Dimensions over all (W x H x D)	244 x 308 x 211 mm
Installation	wall mounting
Mounting position	horizontal
Weight**	approx. 6,5 kg
Housing / Colour	stainless steel / natural
Gas wetted materials (depending on configuration)	PVDF, SS316Ti, FFKM, Duran glass
Dead volume per gas path	67 ml
Connection sample gas and condensate outlet with condensate pump	PVDF-hose fitting DN 4/6 for SS: pipe 6 mm
Condensate outlet without condensate pump	1/4" NPTf or 3/8" NPTf for SS: pipe 12 mm
Approvals / Signs	CE

Electrics

Power supply	230 VAC 50/60 Hz +/- 10 % or 115 VAC 50/60 Hz +/- 10 %
Power consumption (depending on load and ambient temperature)	30 to 160 VA
Connection power	IEC plug
Protection class (in default mounting position)	IP 20 (EN 60529)
Fusing	lead fuse T2A in IEC plug
On time	100 %
Diagnostic / Operation indicator	1 x bicolour LED with condensate detector: 2 x bicolour LEDs
Status threshold	< 0 / > +10 °C
Status delay	0,5 s
Status relay	volt free contact, 230 VAC / 2 A, min. 5 VADC / 5 mA
Connection terminals / Clamping range	spring type terminals 0,5 mm ² to 2,5 mm ²
Threshold condensate detector	factory setting 12 kΩ adjustable 2 to 30 kΩ

* Results from the effective cooling capacity at 20 °C ambient temperature and 5 °C outlet dew point and can be influenced by further operational parameters.

** Dependent on configuration

GAS FLOW DIAGRAMS

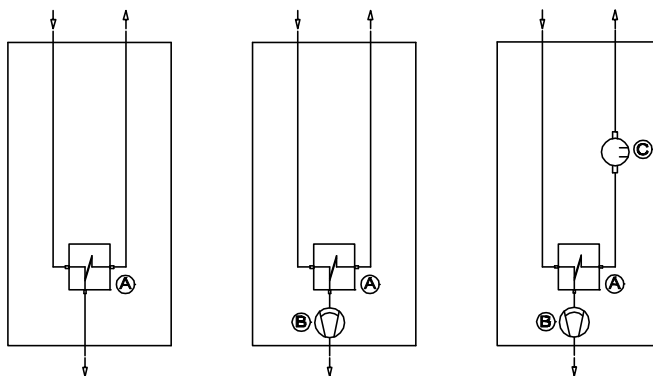

A	Actively cooled heat exchanger
B	Condensate pump (option)
C	Condensate monitoring (option)

ORDER CODE

JCM-300 series

Heat exchanger	JHEX-4 heat exchanger PVDF	2				
	JHEX-4 heat exchanger Duran glass	3				
	Heat exchanger SS-GLY (helical style)	5				
Condensate pump	with condensate pump JSR-25		1			
	without condensate pump JSR-25, 1/4" NPTf outlet		3			
	without condensate pump JSR-25, 3/8" NPTf outlet		4			
Condensate detectors	without condensate detector			0		
	with condensate detector			1		
Power supply	230 VAC 50/60 Hz				A	
	115 VAC 50/60 Hz				B	

Order code	JCM-300.	█	█	█	█	█
-------------------	----------	---	---	---	---	---

DIMENSIONS

Dimensions in mm

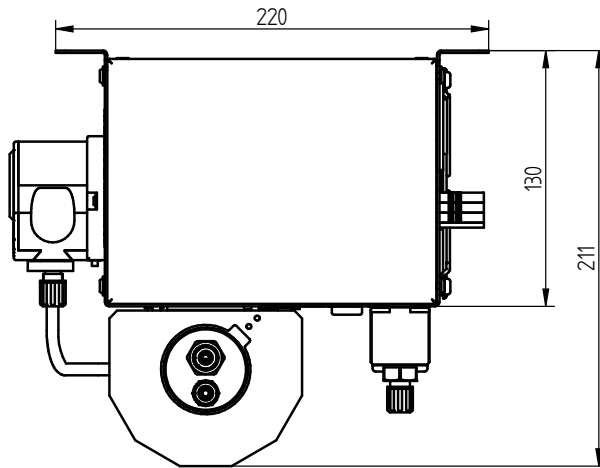
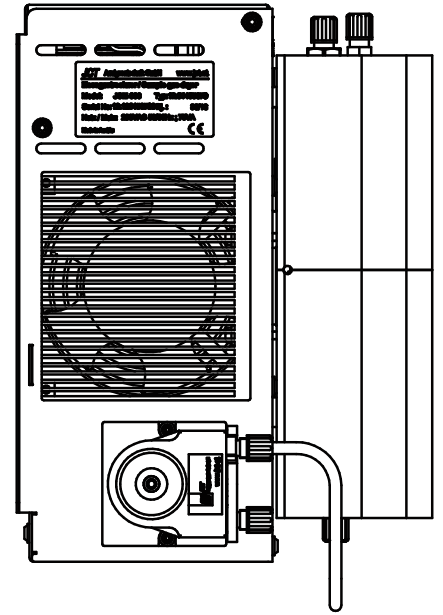
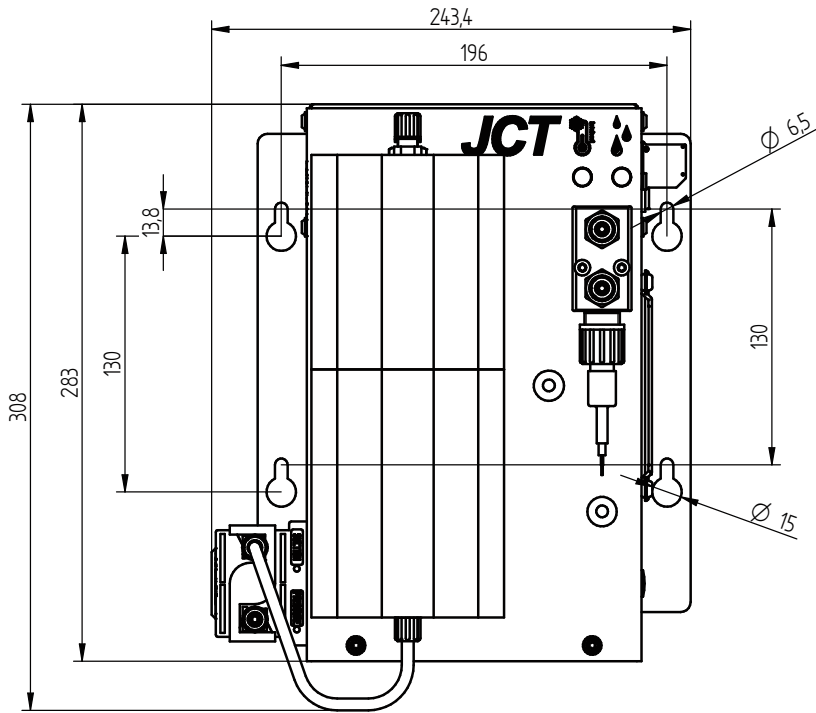

Gas Sampling Probes



Heated Sample Lines



Sample Gas Coolers



JCT
Analysentechnik

Gas Conditioning Systems



NOx Converter



and solutions for

