

# SAMPLING DEVICE SERIES FOR GAS ANALYZER

## DATA SHEET

**GAS EXTRACTOR**  
(model: ZBA)  
Page 2

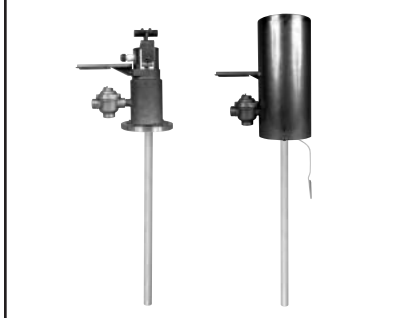

**GAS FILTER  
GAS WASHING SEPARATOR  
AND WASHING NOZZLE  
SO<sub>3</sub> MIST CATCHER  
Component eliminator**  
(model: ZBB□) Page 6

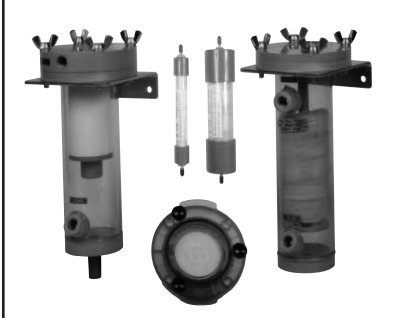

**PELTIER GAS COOLER (model: ZBC)  
GAS DRYER (model: ZBJ)**  
(Semi-permeable membrane vapor phase dehumidifier)  
Page 9



**FLOW METER AND REGULATOR**  
(model: ZBD)  
Page 12



**BALL VALVES AND SELECTOR VALVES**  
(model: ZBF)  
Page 14

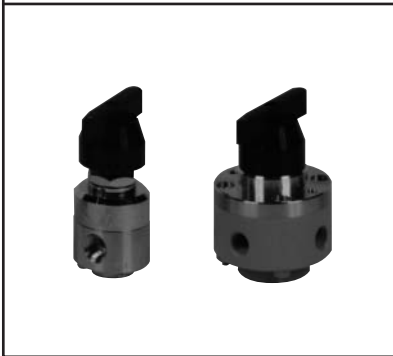

**GAS ASPIRATOR**  
(model: ZBG)  
Page 15



**DRAININGS & OTHERS**  
(model: ZBH)  
Page 16



**GAS CONVERTER**  
(model: ZDL)  
Page 18



**STANDARD GAS**  
(model: ZBM)  
Page 20



# ■ GAS EXTRACTOR (model: ZBA)

## SPECIFICATIONS

Type	ZBAK2	ZBAS1	ZBAB
System	Electric heating (Standard type)	Electric heating (Applicable to high dust)	For cleaning gas extraction (Without filter)
Gas temperature	800°C max./SUS probe 1300°C max./SiC probe (Note 1)	800°C max./SUS probe	100°C to 800°C (ZBAB0W) 100°C to 1000°C (ZBAB1T)
Features	Electric heating system applicable to high temperature Amount of dust (guideline): Up to 100mg/Nm <sup>3</sup>	Applicable to large amount of dust Amount of dust (guideline): Up to 20g/Nm <sup>3</sup>	Simple type intended for the environment relatively small in amount of dust Amount of dust (guideline): Up to 10mg/Nm <sup>3</sup>
Material of part contacting gas	SUS316, Viton	SUS316, Viton	SUS316, 304 (ZBAB0W) Titanium (ZBAB1T)
Sampling pipe	SUS 316, SiC	SUS 316	SUS316, 304 (ZBAB0W) Titanium (ZBAB1T)
Companion flange	JIS 5k 65AFF (Note 2)	JIS 10k 50AFF (Note 2)	JIS 5k 65AFF (ZBAB0W) (Note 2) JIS 5k 25AFF (ZBAB1T)
Filter	SUS316 mesh, Filtering capacity: 40µm	SUS316 mesh, Filtering capacity: 10µm	—
Response time (excluding sampling pipe)	90% response at 3L/min: Approx. 25s	90% response at 3L/min: Approx. 16s	90% response at 3L/min: Approx. 8s
Mass (approx.)	9kg (Excluding sampling pipe)	20kg (Excluding sampling pipe)	3.5kg (Excluding sampling pipe)
Sample gas outlet	Rc1/2	Rc1/2	Rc1/2
Heater	100V AC 100VA	100V AC 400VA	—
Installation	Outdoor installation		

Note 1) The flow rate of sample gas should be kept at 1L/min. or lower for applications to high temperature gases.

Contact us for applications to gases at flow rate higher than 1L/min.

Note 2) Flange of other specifications are also available. Contact us for details.

## CODE SYMBOLS

1 2 3 4 5 6 7 8 9 10 11	Description	Details of selection
Z B A - - - - -	<b>System (4th, 5th, and 6th digits)</b>	
B 0 W	Unheated type, SUS	
B 1 T	Unheated type, titanium	
K 2 W	Electric heating type (Standard)	
S 1 W	Electric heating type (Applicable to high dust)	
	<b>Insertion length (L) (7th digit)</b>	
Y	0mm	*ZBAS: Specify one from Y to K. *ZBAB: Specify one from Y to G. *Material of ZBAB1: Titanium Gas temperature: 1000°C max. *ZBAK: Any one can be specified.
A	300mm	
B	400mm	
C	600mm	
E	800mm	
G	1000mm	
H	1200mm	
J	1500mm	
K	2000mm	
D	700mm	
F	900mm	
	<b>Gas output joint (9th digit)</b>	
	Nipple	Current tap socket
0	Without	Without
2	For ø10/ø8mm Teflon tube	Without
5	Without	With
7	For ø10/ø8mm Teflon tube	With
A	For ø10/ø8mm Teflon tube (Elbow)	Without
	<b>Flange (10th digit)</b>	
A	JIS 5k 65AFF	
G	JIS 5k 25AFF	
	<b>Heating tube terminal support (11th digit)</b>	
Y	Without	ZBAB0, 1: Specify this.
A	With	

# OUTLINE (Unit: mm)

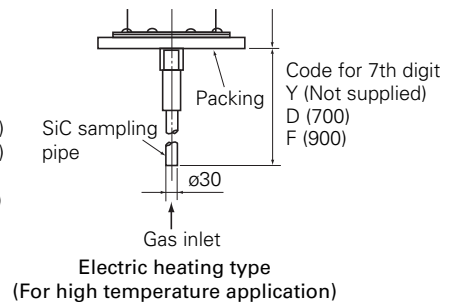
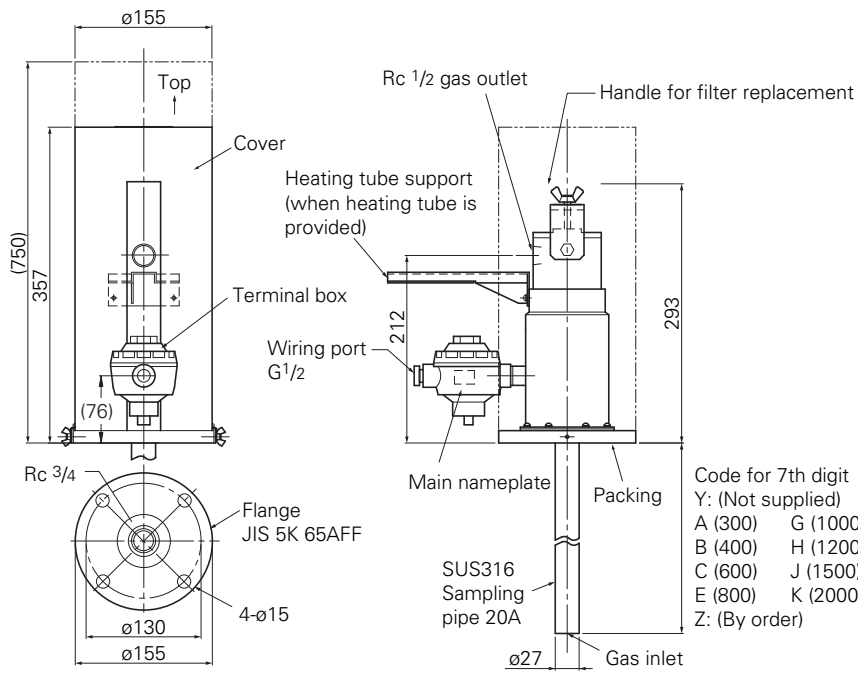

(ZBAK2)

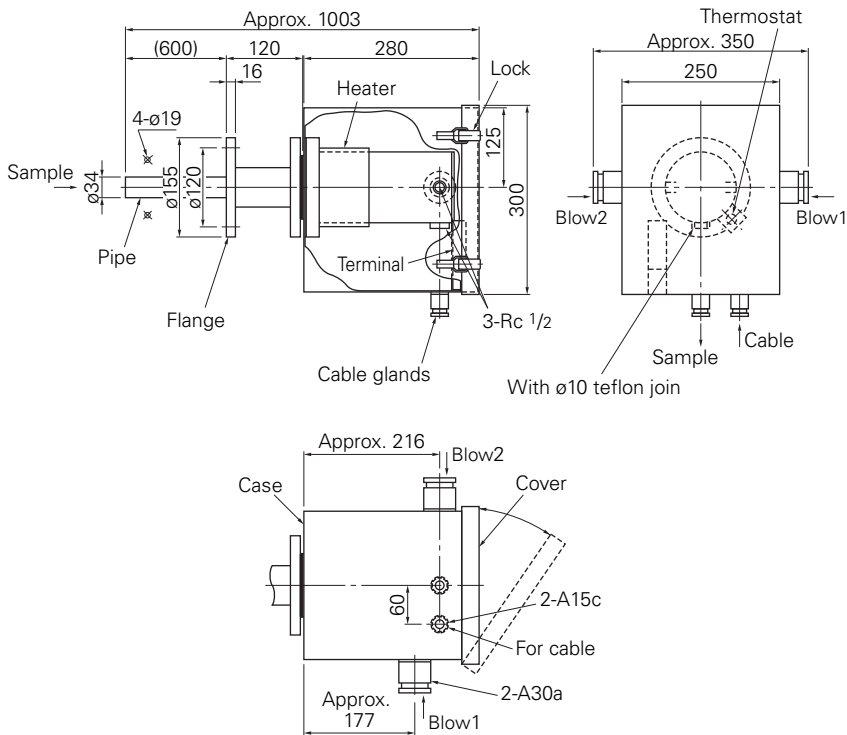

(ZBAS1)

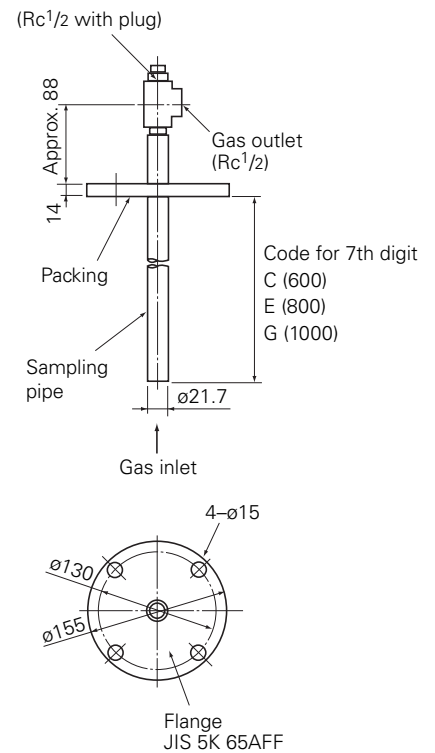

(ZBAB0W)

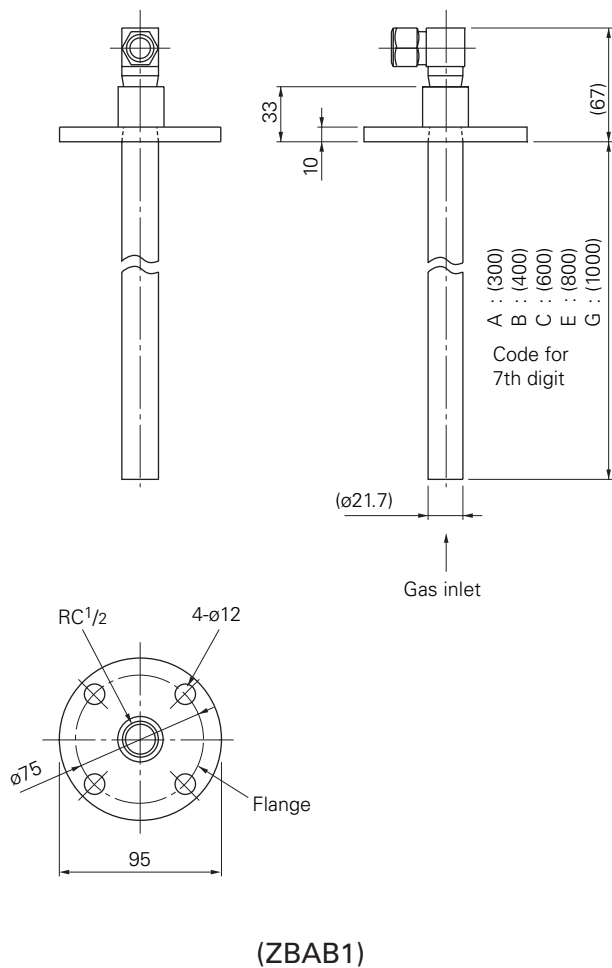

### Gas outlet joint

Coupling for  $\phi 10/\phi 8$  (internal diameter) Teflon tube

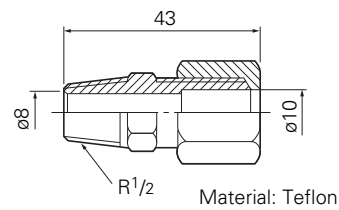

(For ZBAK, ZBAB0)

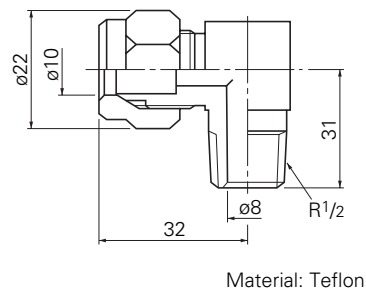

### Current tap socket

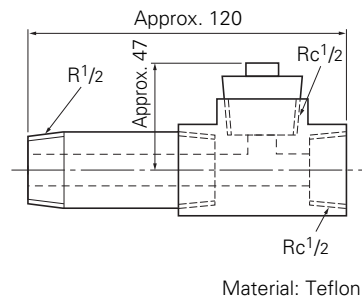

(Unit: mm)

## SCOPE OF DELIVERY

**ZBAK2** : Main unit, sampling pipe, packing for flange  $\times$  1, bolt and nut  $\times$  4, O-ring (G50, G45)  $\times$  1 each or 2 each (for high temperature application)

**ZBAS1** : Main unit, sampling pipe, packing for flange  $\times$  1, bolt and nut  $\times$  4, O-ring (G50)  $\times$  1, O-ring (G65)  $\times$  1

**ZBAB** : Main unit, sampling pipe, packing for flange  $\times$  1, bolt and nut  $\times$  4

## CONSUMABLE PARTS/SPARE PARTS

Name	Order code	
Spare parts of ZBAK2 for 1 year (for general application)	ZBN5BA3	Wire mesh filter $40\mu\text{m}$ $\times$ 1, O-ring (G50, G45) $\times$ 1 each, Packing for wire mesh filter $\times$ 1
Spare parts of ZBAK2 for 1 year (for high temperature application)	ZBN5BA4	Wire mesh filter $\times$ 1, O-ring (G50, G45) $\times$ 2 each, Packing for wire mesh filter $\times$ 2
Spare parts of ZBAS1 for 1 year	ZBN3BA6	Wire mesh filter $10\mu\text{m}$ $\times$ 2, O-ring (G50) $\times$ 4, O-ring (G65) $\times$ 4
Wire mesh filter $40\mu\text{m}$ (for ZBAK2)	ZBNL1012	For ZBAK1, 2
O-ring (G50) (Pack of 10)	ZBNN1152	For ZBAK2, ABAS1
O-ring (G45) (Pack of 10)	ZBNN1182	For ZBAK2
Packing for wire mesh filter (Pack of 10)	ZBNN1162	For ZBAK2
Coupling for $\phi 10/\phi 8\text{mm}$ Teflon tube	TK745559P1 TK745559P2 TK745559P10	For ZBAK1 (R $1/4$ ) For ZBAK2, ABAB0 (R $1/2$ ) For ZBAB1 (R $1/2$ elbow)

# ■ GAS FILTER (model: ZBB)

## SPECIFICATIONS

### 1. Gas Filter

Model	ZBBB1V03	ZBBB2V03	ZBBB3V03 / ZBBB4V03
Application	Primary filter for gas without drain	For elimination of SO <sub>2</sub> and SO <sub>3</sub>	For elimination of SO <sub>3</sub>
Filter material	Glass wool	Steel wool (Bonstar #0) (about 200 g)	Ceramic
Materials of gas-contacting parts	PVC (transparent) , chloroprene (O-ring)		PVC (transparent)
Operating temperature	0°C to 45°C		
Withstanding pressure	50kPa		
Filter replacement	Required when about half of the filter element is contaminated by dust. Steel wool filter requires replacement when it is deteriorated.		At SO <sub>3</sub> concentration of 30ppm: Replace once in 4 months (ZBBB3). Replace once in 8 months (ZBBB4).
Connection port	Gas inlet and outlet Rc 1/4		Hose end ø6, Upright attachment
Mass (approx.)	0.8 kg	1 kg	0.1 kg / 0.3 kg
Response time (at flow rate 1L/min)	About 30 sec for 90% indication		
Pressure resistance	About 0.1 kPa (at 5L/min)		About 4 kPa (at 1L/min)

## CONSUMABLE AND SPARE PARTS

### For 1-year analysis

- ZBN3BB12 (for ZBBB1V03)  
Glass wool × 36, O-ring (G65) × 2
- ZBN3BB22 (for ZBBB2V0)  
Steel wool × 3, O-ring × 2
- ZBN3BB82 (for ZBBB3V)  
Replacement mist catcher × 3, Ancillary fitting × 1
- ZBN3BB92 (for ZBBB4V)  
Replacement mist catcher × 2, Ancillary fitting × 1

## OUTLINE ( Unit : mm )

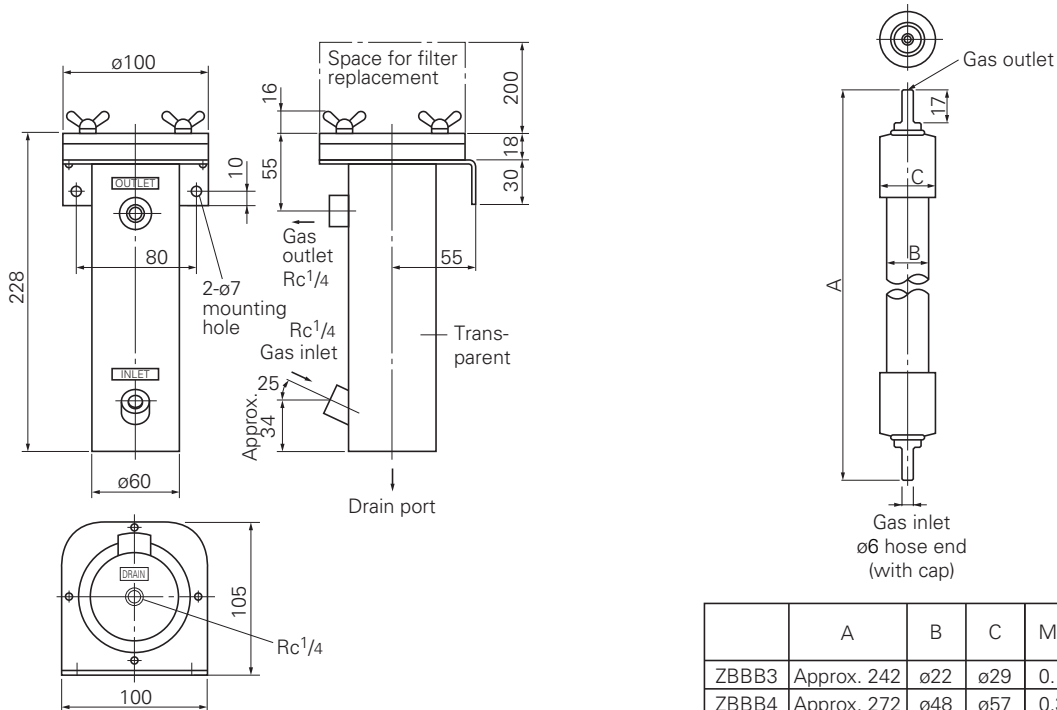

Gas filter  
(ZBBB1V03/ZBBB2V03)

SO<sub>3</sub> Mist catcher  
(ZBBB3V/ZBBB4V)

## 2. Membrane Filter

Type	ZBBM2V□3	ZBBM6V03	ZBBM4V□3	ZBBM7V03
Application	Final-stage filter and monitoring filter of analyzer			
Main materials of gas-contacting parts	Filter element: Glass fiber filter paper (ø55) O-ring : Chloroprene Body : PVC (transparent)		Filter element: Teflon (ø55) O-ring : Chloroprene Body : PVC (transparent)	
Connection port	Gas inlet and outlet Rc1/4	Gas inlet and outlet ø6.4 hose port	Gas inlet and outlet Rc1/4	Gas inlet and outlet ø6.4 hose port
Operating temperature	-10°C to 45°C			
Withstanding pressure	30 kPa (7th code 2 or 3) 5 kPa (7th code 0)			
Response for 90% indication	Approx. 3 sec (at 1L/min) with standard type (7th code 0) Approx. 1.5 sec (at 1L/min) with high speed type (7th code 1 or 3)			
Installation	On vertical panel face (gas inlet being bottom, outlet being top)			
Mass	Approx. 160 g			
Pressure resistance	Approx. 0.1 kPa (at 1L/min)		Approx. 4.3 kPa (at 1L/min)	

□ : CODE  
 0 : general  
 1 : small volume type  
 2 : 30kpa pressure type  
 3 : 1+ 2

## CONSUMABLE AND SPARE PARTS

Part name	Body type				Remarks
	ZBBM2V	ZBBM6V	ZBBM4V	ZBBM7V	
Filter paper ZBNC6102	12 to 50 sheet /year				100 sheet / 1 box
Fluoropore filter paper ZBN C6302			6 to 24 sheets /year		10 sheet / 1 box

For 1-year analysis

- ZBN3BB52 (for ZBBM2)  
Filter paper 25 sheets, O-ring G65 x 1, P49 x 1
- ZBN3BB72 (for ZBBM4)  
Fluoropore filter 12 sheets, O-ring G65 x 1, P49 x 1
- ZBN3BBA2 (for ZBBM6)  
Filter paper 25 sheets, O-ring G65 x 1, Rubber ring x 1
- ZBN3BBB2 (for ZBBM7)  
Fluoropore filter 12 sheets, O-ring G65 x 1, Rubber ring x 1

## OUTLINE ( Unit : mm )

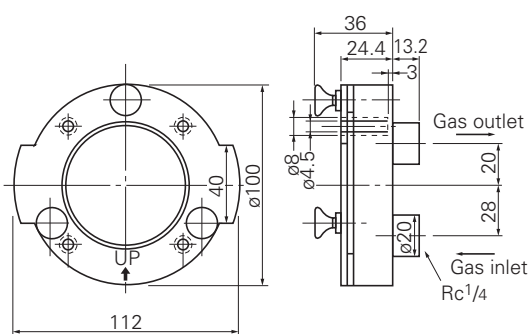

Membrane filter  
(ZBBM2V, ZBBM4V)

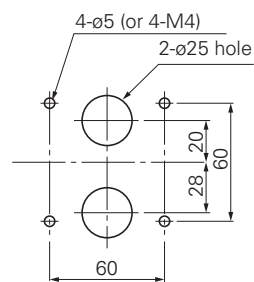

Panel mounting dimensions  
(ZBBM2V, ZBBM4V)

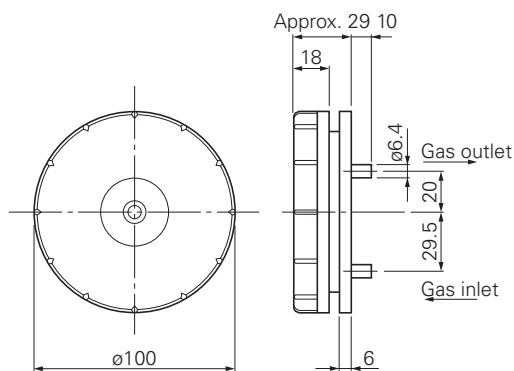

Membrane filter  
(ZBBM6V, ZBBM7V)

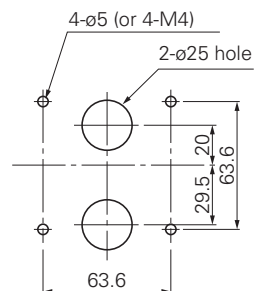

Panel mounting dimensions  
(ZBBM6V, ZBBM7V)

### 3. Mist filter

Model	ZBBK1V03	ZBBK2V03	ZBBK4V03
Application	Drain separation, mist/dust removal, for general exhaust gas	Drain separation, dust removal, for SO <sub>2</sub> analysis, for comparatively clean exhaust gas	Same as left (with space for drain separation)
Main materials of gas-contacting parts	Glass fiber Cellulose Phenol resin Chloroprene PVC	Polyethylene  Chloroprene  PVC	
Pore size	Double structure of approx. 40 and 5μm	approx. 5μm	
Operating temperature	0°C to 45°C		
Connection port	Rc1/4		Inlet/outlet Rc1/4 Drain port: ø13 hose port
Withstanding pressure	20kPa		
Internal volume	Approx. 200 cm <sup>3</sup>		Approx. 300 cm <sup>3</sup>
Response time	Approx. 4 sec for 90% indication (at flow rate 5L/min)		Approx. 7 sec
Installation	Vertical installation on wall face		
Mass	Approx. 0.6 kg		
Pressure resistance	(Dry) Approx. 0.1 kPa (flow rate 5L/min) (Wet) Approx. 0.4 kPa (flow rate 5L/min)	Approx. 0.35 kPa (flow rate 5L/min) Approx. 2.6 kPa (flow rate 5L/min)	

### CONSUMABLE AND SPARE PARTS

- (1) Filter element
  - ZBNH2012 (for ZBBK2, 4)  
2 pcs/set
  - ZBNH1002 (for ZBBK1)  
1 pc./set
  - ZBNH2002 (for ZBBK2)  
1 pc./set
- (2) O-ring (JISG65)
  - ZBNN1012 (For ZBBK1, 2, 4)  
(10 pcs/set)
- (3) Requirement for 1 year (guideline when used for oil burning exhaust gas)
  - ZBN3BB32 (for ZBBK1)  
(Filter × 3, O-ring G65 × 2)
  - ZBN3BB42 (for ZBBK2, 4)  
(Filter × 3, O-ring G65 × 2)

### 4. Component eliminator

Item	Component eliminator			
	NOx SO <sub>2</sub> scrubber	NOx SO <sub>2</sub> scrubber	CO <sub>2</sub> scrubber	
Type of reference gas (product type to be used with)	Air (ZPB,ZPG)	Sample gas (ZPG)	Sample gas( ZPB,ZPG)	
Type	Main unit	ZBBB6V03	ZBBB7V03	
Catalyst	Usage amount	50g	300g	
	Replacement cycle	1 year (*1)	6 months (*2)	
Specification of eliminator	Conversion efficiency	99.5% or more	99.5% or more	
	Gas flow rate	1L/min	1L/min	
	Ambient temperature	0 to45°C	0 to 45°C	
	Mass.	Approx.200g (*1)	Approx.800g (*2)	
	Gas condition	Temperature 0 to 40°C	Temperature 0 to 40°C	Temperature 0 to 40°C
		Pressure 30kPa or less	Pressure 30kPa or less	Pressure 30kPa or less
		no moisture (2°C saturation or less) no dust (particle size 0.3μm or less ,100μg/Nm3 or less)		
		(*1) If each of Nox and SO <sub>2</sub> is about 0.5ppm	(*2)If NOx+SO <sub>2</sub> is 10ppm or less (do not contain other acid gas)	(*3) If CO <sub>2</sub> is 0.5ppm
	Spare item	(Replace the whole main unit)	(Replace the whole main unit)	(Replace the whole main unit)

### OUTLINE ( Unit : mm )

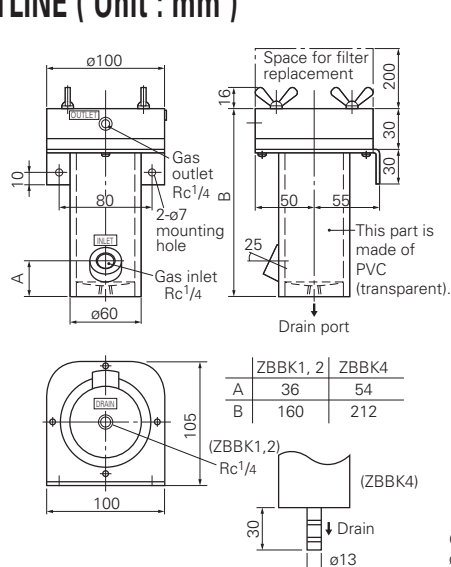

Mist filter (ZBBK)

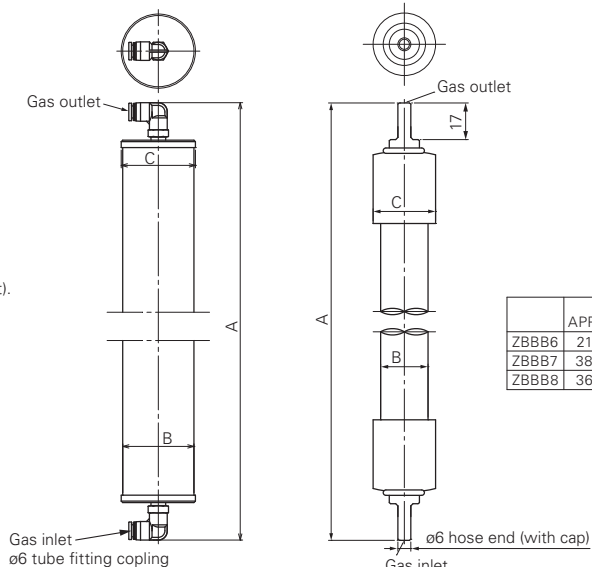

Component eliminator (ZBBB6V, 7V)

Component eliminator (ZBBB8V)

	A APPROX.	B	C	MASS APPROX.
ZBBB6	219±10	ø38	ø46	0.2kg
ZBBB7	384±10	ø48	ø57	0.8kg
ZBBB8	364±10	ø22	ø29	0.2kg

## 5. Gas Washing Separator and Washing Nozzle

**Model:** Washing nozzle (ZBBH2 W03-0)  
Gas washing separator (ZBBF□W03-△)

**Functions:** Suction of dusty gas, washing with water and separation of water and gas

**Washing water:** 100 to 200 kPa, Typically 5 to 10L/min depending on furnace pressure and sampling pressure loss

**Suction rate:** Approx. 8L/min (water volume 8R/min, 160 mm water sealing, vertical piping of 1 m length)

**Ambient temperature:** 0°C to 60°C

**Connection port:** Washing nozzle;

Washing nozzle inlet	Rc1/2
Gas inlet	Rc1 1/4
Outlet	Rc1/2
Blowback air inlet	Rc1/2

Gas washing separator;

Inlet	R1/2
Gas outlet	R1/2
Water outlet	R1
Drain port	Rc1/2

**Main material of gas-contacting parts:**  
SUS 316

**Mass:** Washing nozzle; approx. 3 kg  
Gas washing separator; approx. 15 kg (ZBBF2W)

**Discharge pressure:**  
2.1kPa at max. (When 2 is selected as the 5th digit of the code symbols)  
5kPa at max. (When 5 is selected as the 5th digit of the code symbols)  
2.1 to 6kPa (When 9 is selected as the 5th digit of the code symbols)

**Gas outlet coupling:**

None (When 0 is selected as the 9th digit of the code symbols)

For  $\phi 10/\phi 8$  mm Teflon tube (When 2, 3 is selected as the 9th digit of the code symbols)

Note: For washing, use the water that has undergone degassing processing. Otherwise indication error of O<sub>2</sub> gauge (in the case of micro O<sub>2</sub> gauge) of decrease of suction flow rate may result.

### Application Example

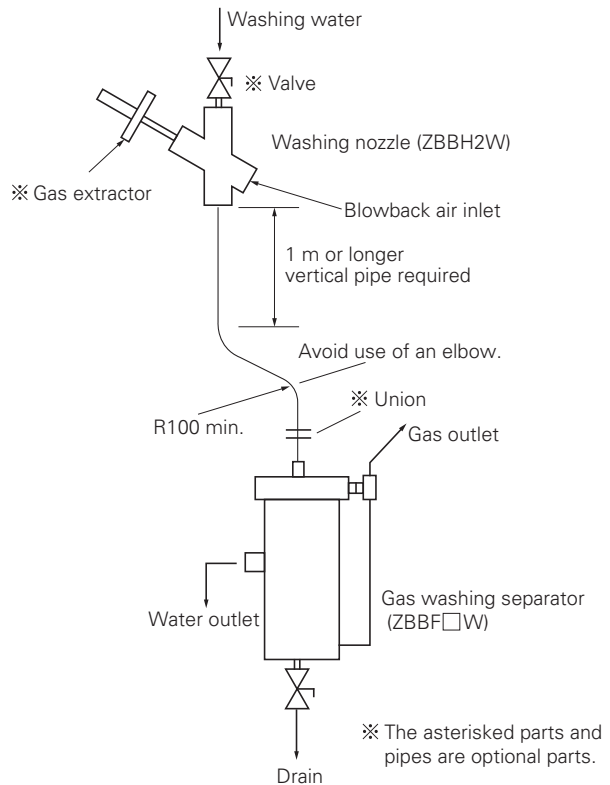

## OUTLINE ( Unit : mm )

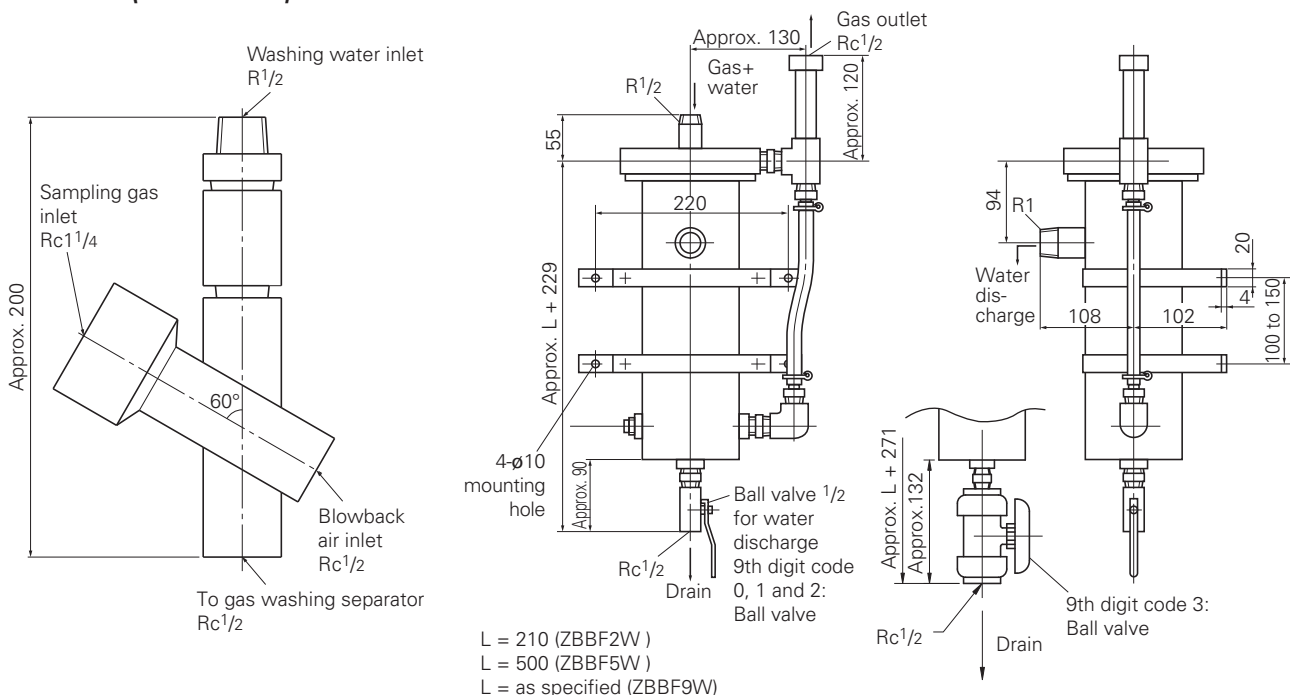

Washing nozzle (ZBBH2W)

Gas washing separator (ZBBF)



# ■ GAS DRYER, GAS COOLER (model: ZBJ / ZBC)

## SPECIFICATIONS

### 1. Gas dryer (Semi-permeable membrane vapor phase dehumidifier)

Type	ZBJ02503-72P	ZBJ16253-48P
Application	Dehumidify sample gas such as flue gas or atmospheric air	
Measuring components	SO <sub>2</sub> , NO, CO, CO <sub>2</sub> , O <sub>2</sub> , HC, H <sub>2</sub> , etc.	
Operating temperature	-15°C to +80°C (No freezing allowed.)	
Mounting angle	Not restricted	
Working pressure	-0.04MPa to +0.5MPa (at 25°C)	
Material	Polypropylene, Fluororesin, Viton	
Dehumidification dew point (Note)	-10°C or lower	-20°C or lower
Standard flow rate	0.5L/min.	1.0L/min.
Pressure resistance (at gas flow rate 1L/min)	Approx. 0.8 kPa	Approx. 2.8 kPa
Internal volume (sample side)	Approx. 12 cm <sup>3</sup>	Approx. 20 cm <sup>3</sup>
Mass	Approx. 100 g	Approx. 350 g

(Note) Dehumidification conditions;  
Depend on the system in application example 2 under flow rate 0.5L/min, pressure 50 kPa and ambient temperature 20 to 22°C.

### Dehumidification Characteristic for Gas Dryer (typical example)

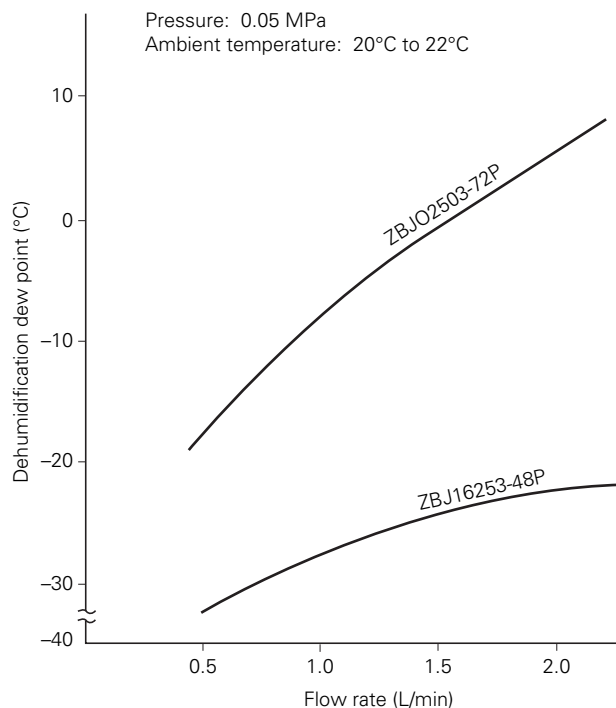

## PRINCIPLE OF GAS DRYER

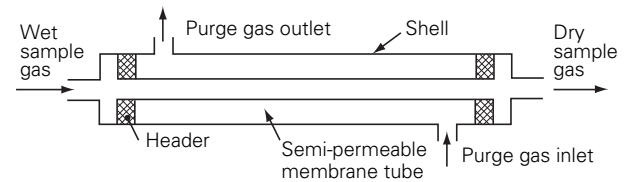

The Gas dryer utilizes the characteristic of the semi-permeable membrane tube that a certain component in a mixed gas is permeated from its higher partial pressure to the lower one.

In the figure, the sample gas containing moisture is introduced through the inlet at the left end. Through the bottom right of the figure, the purge gas having a lower pressure and less moisture than the sample gas is injected. Then, moisture is removed from the wet sample gas due to the action of the semi-permeable membrane tube and discharged through the purge gas outlet. Thus, the sample gas is dried and becomes the dry sample gas to be discharged.

## GAS DRYER

### Application example 1: When dry purge gas is supplied separately;

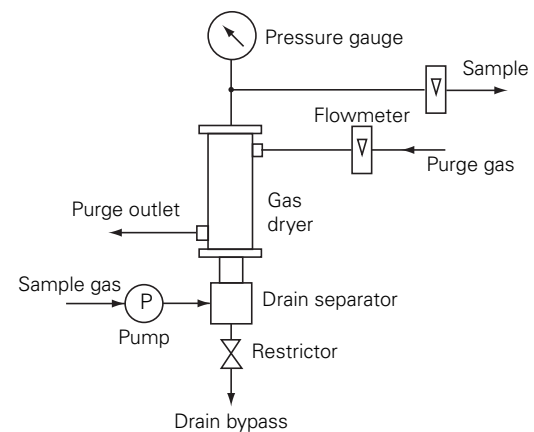

- 1) The purge outlet must be open to the atmosphere.
- 2) Although a higher sample pressure is preferable, it should normally be 0.1 MPa at maximum and atmospheric pressure at minimum.
- 3) The pressure gauge, when provided, is helpful for monitoring the operational status.
- 4) If drain occurs due to pressurization by the pump, it should partially be bypassed with the drain separator.
- 5) The volume of purge gas should be 2 to 5 times as large as that of sample gas.

## Application example 2: When all volume of sample gas is usable for purge gas;

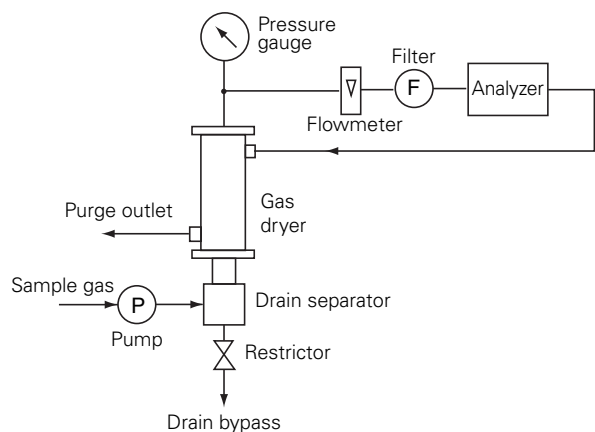

- 1) The purge outlet must always be open to the atmosphere.
- 2) A higher sample pressure is advantageous. The pressure should normally be 0.1 MPa at maximum and 0.05 MPa at minimum. If the pressure is low, an adequate dehumidification effect may not be obtainable.
- 3) The pressure gauge, when provided, is helpful for monitoring the operational status.
- 4) If drain occurs due to pressurization by the pump, it should partially be bypassed with the drain separator.

### Caution on Use

1. Establish the flow path so dry gas flows on the face opposite to the semi-transparent face that contact the gas to be dried as shown by the example of use.
2. Dust should be removed by installing a filter of filtration accuracy 5 $\mu$ m or less before the dryer. Oil mist should also be disposed before the dryer.
3. If water drops enters the semi-permeable membrane tube, only the water permeates the membrane and the salts dissolved in the water are precipitated to cause clogging. Therefore, the flow path should be designed so as not to allow entrance of water drops.
4. This dryer has a large drying capacity and can reduce humidity, but cannot maintain humidity at a constant level by the ordinary usage. For using this dryer as a humidity conditioner, the flow rate, pressure and temperature need to be kept constant.
5. This dryer is unusable for gases of alcohol, ketone, and high-concentration ammonia, and those containing steam and NO<sub>2</sub> more than 100 ppm.

## OUTLINE ( Unit : mm )

### Gas dryer

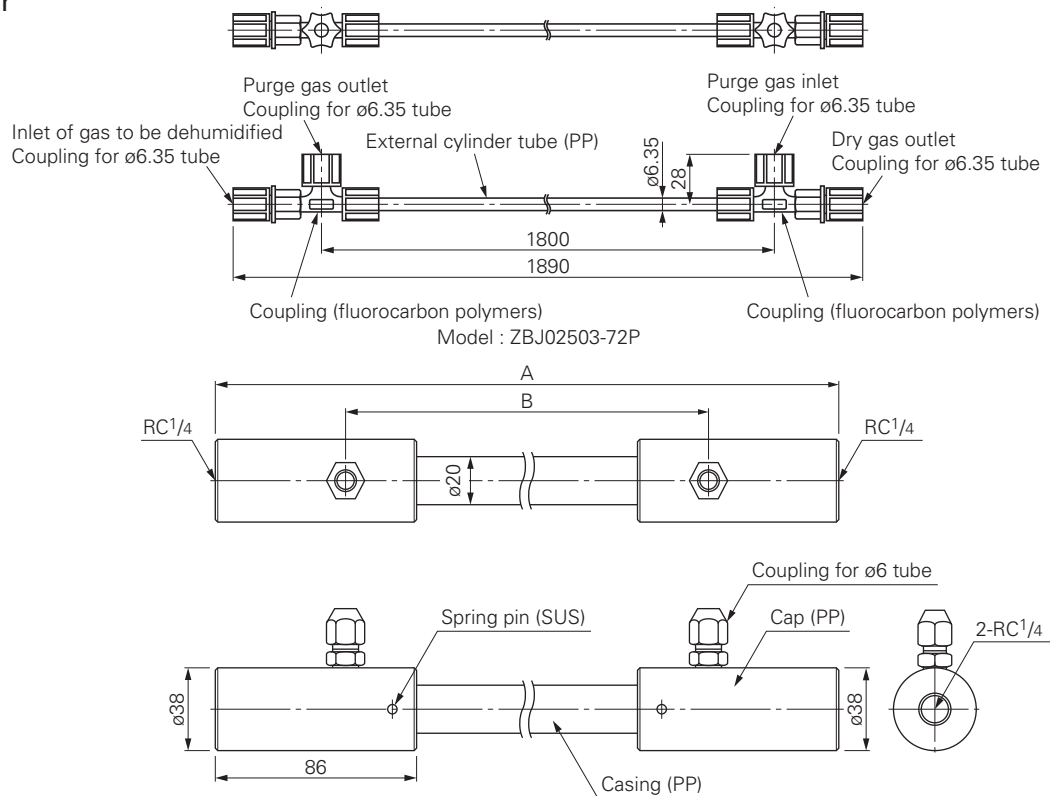

Model	A APPROX.	B APPROX.	MASS APPROX.
ZBJ16253-24P	714	600	250g
ZBJ16253-48P	1314	1200	355g

Model : ZBJ16253-

24
48

P

## 2. Peltier gas cooler

Model	ZBC91004	ZBC92004	ZBCA2004
System	1-channel corrosion-proof type		2-channel corrosion-proof type
Flow rate (max.) (For constant dehumidification)(max.)	1.5L/min	Parallel piping 1.5L/min (1-channel)x2	Series piping 3L/min Parallel piping 1.5L/min (1-channel)x2
Outlet gas dew point Short-time ripple	1°C to 3°C ±0.1°C		1°C to 5°C ±0.1°C
Flow rate (max.) (For prevention of condensation)(max.)	5.0L/min (dew point 0.5°C to 10°C)	10L/min (dew point 0.5°C to 10°C)	
Dehumidification level check function	T thermocouple (built in)		
Limit conditions	Ambient temperature (max.) / Inlet gas temperature (max.) / Inlet gas dew point (max.) : 40°C		
Main materials of gas-contacting parts	Carbon, Fluoro rubber, Fluoro resin, HDPE, PVC		SUS304, SUS316, Teflon, PVC, Fluoro rubber
Enclosure material	SUS430		
Gas inlet/outlet	Rc1/4		Gas inlet, outlet: $\phi 11/\phi 5$ hole Drain: $\phi 13/\phi 9$ hole
Working pressure (max.)	60kPa		50kPa
Ambient temperature	2°C to 40°C		
Ambient humidity (max.)	90%RH		
Power supply	100V10V AC, 50/60Hz		
Power consumption (approx.)	140VA	200VA	
Mass (approx.)	4kg	5kg	
Scope of delivery	Body, spiral pulling out tool x 1		Body, Toaron tube, Hose band

(Note) Do not use gases containing organic solvent such as toluene, xylene, etc.

## OUTLINE ( Unit : mm )

### Electronic gas cooler

#### 1) Model: ZBC91004

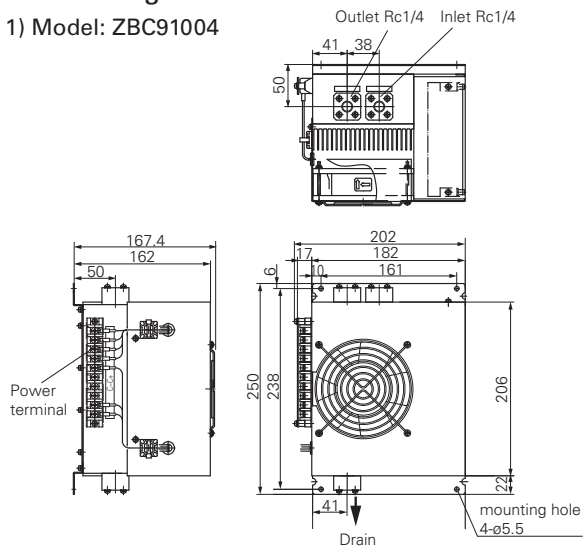

#### 2) Model: ZBC92004

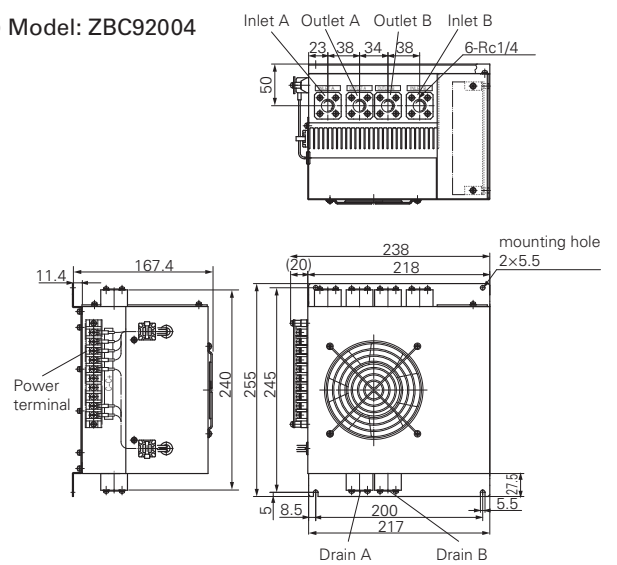

#### 3) Model: ZBCA2004

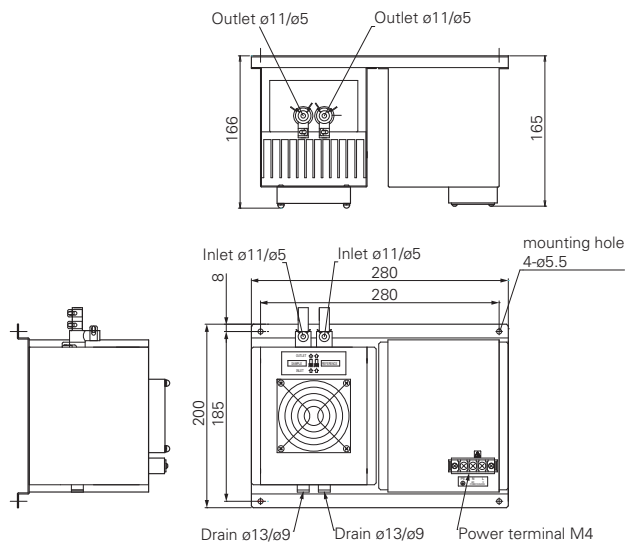

### Wiring diagram

#### Model: ZBC91, 92

For internal connection

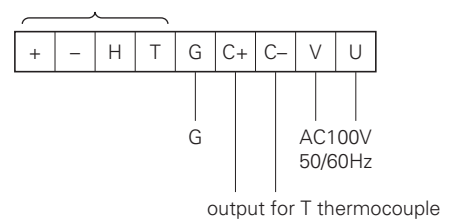

# ■ FLOWMETETER, REGULATOR (model: ZBD)

## SPECIFICATIONS

### 1. Pressure Regulator

Type	ZBD61003	ZBD62003	ZBD63003	ZBD64003
Application	Right-hand thread for pressure adjustment of standard gas For general use (note)	Left-hand thread for pressure adjustment of standard gas For general use (note)	Right-hand thread for pressure adjustment of standard gas For corrosion prevention (note)	Left-hand thread for pressure adjustment of standard gas For corrosion prevention (note)
Primary pressure	Max. 14.7 MPa	Max. 14.7 MPa	Max. 14.7 MPa	Max. 14.7 MPa
Secondary pressure	Variable from 0 to 0.12MPa	Variable from 0 to 0.12MPa	Variable from 0 to 0.15MPa	Variable from 0 to 0.15MPa
Connection	Standard gas container Right-hand 22/14 threads Gas outlet Rc 1/4	Standard gas container Left-hand 22/14 threads Gas outlet Rc 1/4	Standard gas container Right-hand 22/14 threads Gas outlet Rc 1/4	Standard gas container Left-hand 22/14 threads Gas outlet Rc 1/4
Main materials of gas-contacting parts	C3604 NBR	C3604 NBR	SUS316 Teflon	SUS316 Teflon
Mass (approx.)	2.2 kg	2.2 kg	0.9 kg	0.9 kg
Scope of delivery	Main unit and accessory (nylon packing for standard gas connection x 3)		Main unit and accessory (Teflon packing for standard gas connection x 3)	

Note) Thread for connection with standard gas container:

Right-hand thread when the specified combustible gas concentration of standard gas is less than 5% in total, and left-hand thread when it is 5% or more.

Application:

For general use; for other than corrosion prevention

For corrosion prevention; When the specified gas concentration of standard gas is 1% CO or more (due to corrosion prevention) or when specifying corrosion prevention

### 2. Needle Valve

Model	ZBD23003	ZBD24003	ZBD25003
Application	Flow rate regulation		
Withstanding pressure	0.1MPa	1.0MPa	
Ambient temperature	-10°C to 45°C	-10°C to 60°C	
Connection port	ø6 hose port	Rc1/4	
Materials of gas-contacting parts	PVC Viton rubber	BSBM2	SUS316
Mass (approx.)	100 g	150 g	130 g
Scope of delivery	Main unit		

### 3. Relief Valve

Model	ZBD35103
Application	Sample gas and drain relief
Settable pressure	40 to 60kPa
Ambient temperature	0°C to 45°C
Connection port	Rc1/4
Materials of gas-contacting parts	PVC Viton rubber Hastelloy C
Mass (approx.)	200 g

### 4. Flow Meter

Model	ZBD5□△03	ZBD4□△03
Application	For general exhaust gas (metal joint unusable)	For dangerous gas, corrosive gas (metal joint usable)
Withstanding pressure	0.49MPa	
Ambient temperature	-10°C to 60°C	
Connection port	Rc1/4	
Materials of gas-contacting parts	POM, hard glass, fluoro rubber	SUS304, hard glass, fluoro rubber
Flow rate scale	6th code (△) 1 : 0.1 to 1L/min 2 : 0.2 to 2L/min 3 : 0.5 to 5L/min 4 : 1 to 10L/min 5 : 2 to 20L/min 9 : As specified (air, atmospheric pressure, 20°C)	
Flow regulating needle valve	5th code (□) 2 : With needle valve (at inlet) 4 : With needle valve (at outlet)(when pump is installed after it) 7 : Without needle valve	
Mass (approx.)	100 g	500 g

### 5. Flow Checker

Model	ZBD71003	ZBD72003
Application	Flow rate monitoring	Flow rate monitoring
Operating pressure	Atmospheric pressure	Atmospheric pressure
Ambient temperature	-10°C to 60°C	-10°C to 60°C
Connection port	ø6 hose port	ø6 hose port
Material of part contacting gas	Glass SUS316 Polyethylene Chloroprene	Glass SUS316 Polyethylene Chloroprene
Flow rate range	Yellow zone 0.3 to 0.7L/min	White zone 0.7 to 1.3L/min
Mass	Approx. 100 g	Approx. 100 g
Scope of delivery	Main unit	Main unit

# OUTLINE ( Unit : mm )

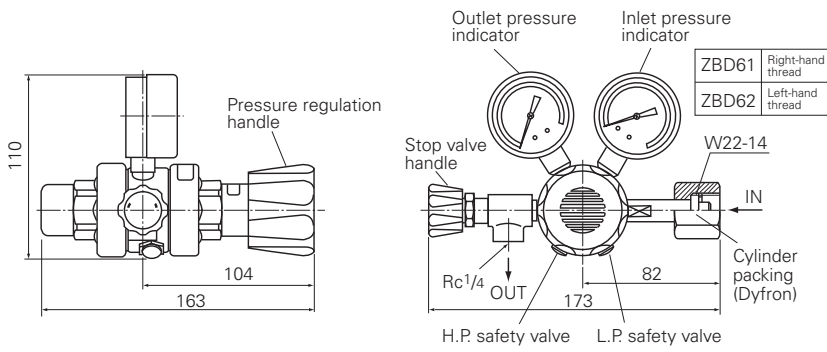

Pressure regulator (ZBD61/ZBD62)

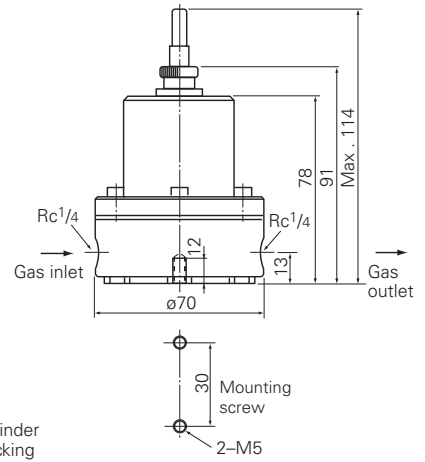

Relief valve (ZBD35)

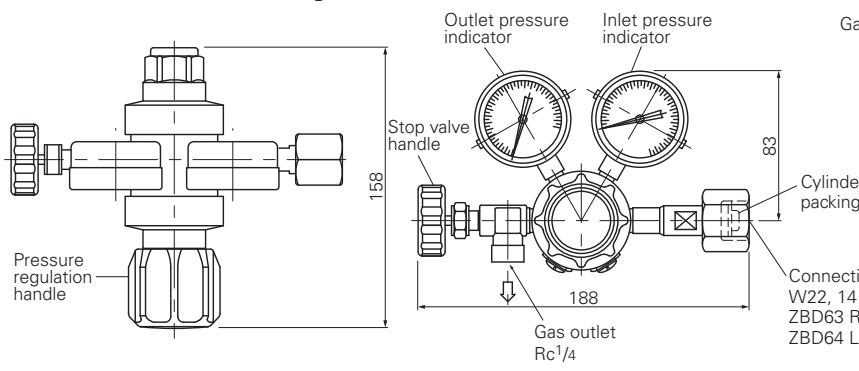

Pressure regulator (ZBD63/ZBD64)

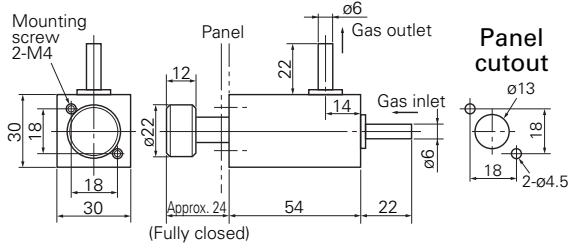

Needle valve (ZBD23)

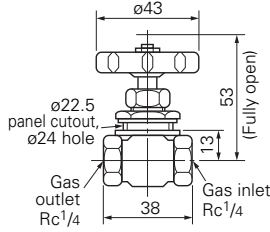

Needle valve (ZBD24)

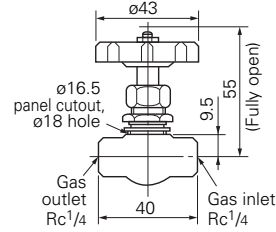

Needle valve (ZBD25)

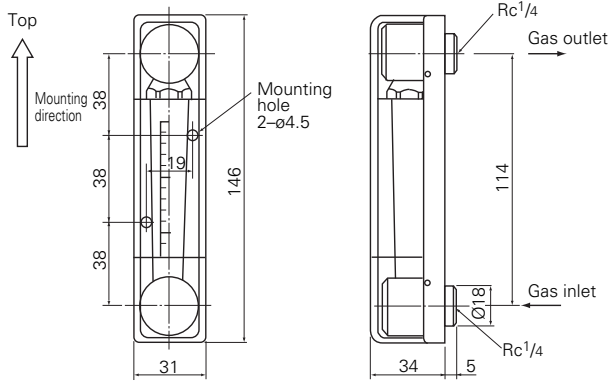

Flow meter (ZBD47)

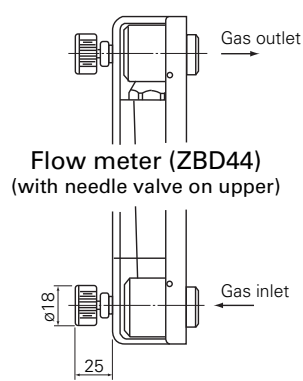

Flow meter (ZBD44)  
(with needle valve on upper)

Flow meter (ZBD42)  
(with needle valve on lower)

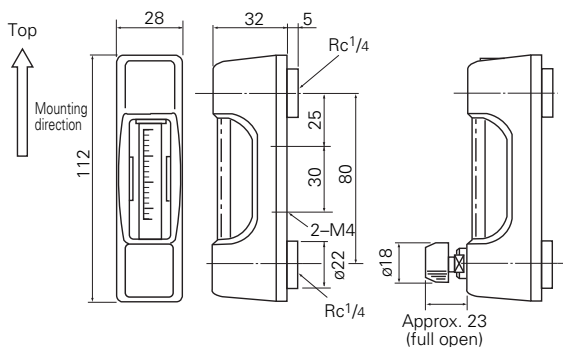

Flow meter (ZBD57)

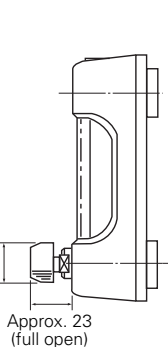

Flow meter (ZBD52)

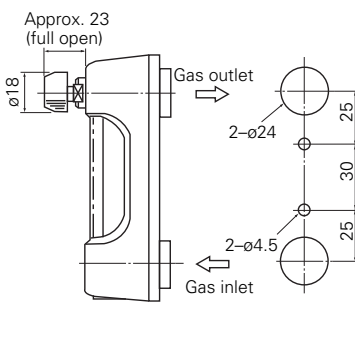

Flow meter (ZBD54)

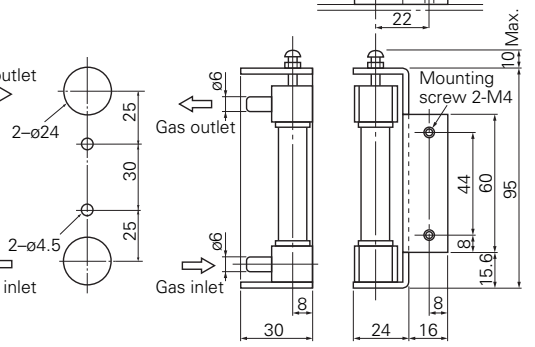

Panel cutout (ZBD5)

# Ball valves and selector valves (model: ZBF)

## SPECIFICATIONS

Item	Kind	Ball valve	2-way valve	4-way valve	4-way valve
Model		ZBFB1 ZBFB2 ZBFB3 ZBFB4	ZBFH2	ZBFH4	ZBFH5
Application		General ball valve	Selection between sample gas and standard gas	Selection between sample gas and standard gas	Selection between sample gas and standard gas (for metal joint)
Withstanding pressure		ZBFB1, 2; 2.0MPa ZBFB3, 4; 4.0MPa	0.3MPa	0.15MPa	0.5MPa
Ambient temperature		-10°C to 80°C	-10°C to 80°C	-5°C to 45°C	-10°C to 80°C
Connection port		ZBFB1, 3; Rc <sup>1</sup> / <sub>4</sub> ZBFB2, 4; Rc <sup>1</sup> / <sub>2</sub>	Rc <sup>1</sup> / <sub>8</sub>	Rc <sup>1</sup> / <sub>8</sub>	Rc <sup>1</sup> / <sub>4</sub>
Materials of gas-contacting parts		ZBFB1, 2; Brass, Teflon ZBFB3, 4; SUS316, Teflon	SUS316 Teflon	PVC Teflon	SUS316 Teflon
Mass (approx.)		200g	230g	250g	500g

## OUTLINE ( Unit : mm )

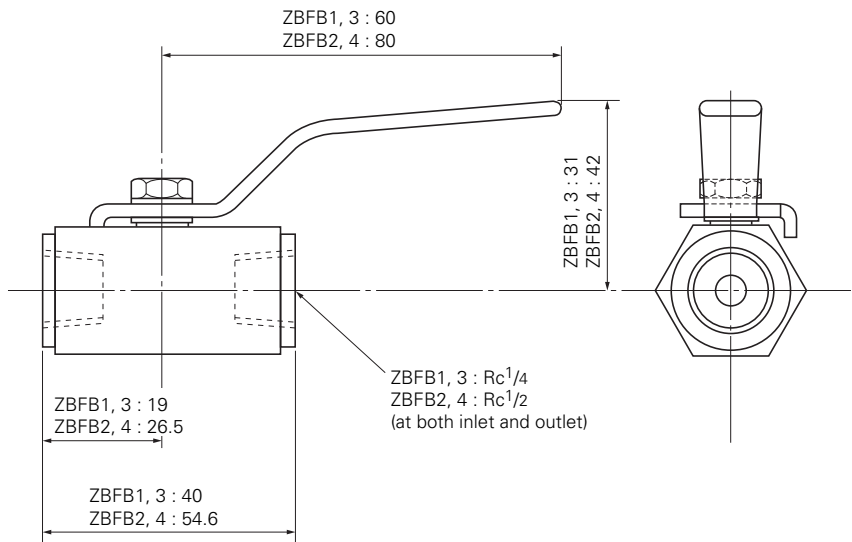

Ball valve (ZBFB)

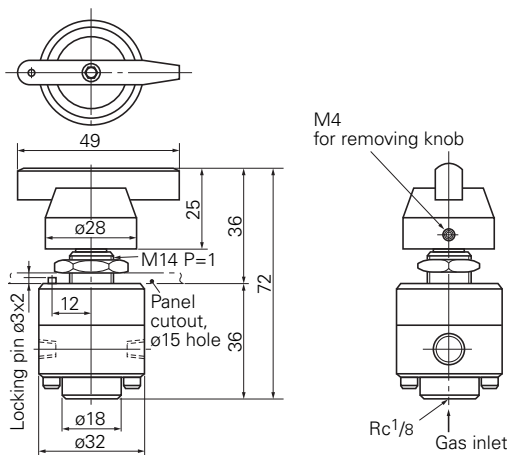

2-way valve (ZBFH2)

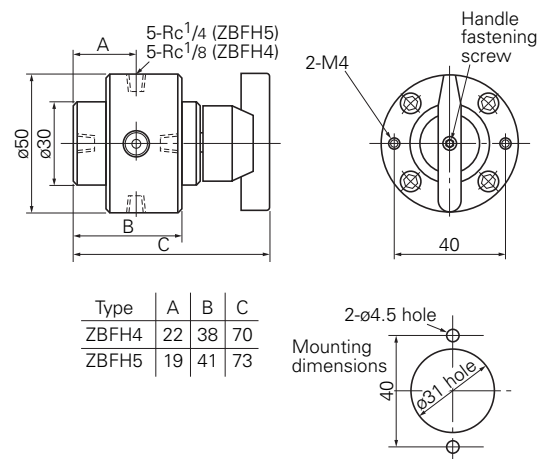

4-way valve (ZBFH4/ZBFH5)

# ■ GAS ASPIRATOR (model: ZBG)

## SPECIFICATIONS

Model	ZBG52004	ZBG62004	ZBG80004
Materials of gas-contacting parts	Diaphragm, valve: Viton Pump head: PP		Diaphragm, valve: Viton Pump head: PPS
Power supply	100V±10V AC, 50/60Hz, approx. 50W		100V±10V AC, 50/60Hz, approx. 30W
Max. vacuum	Approx. -59.9kPa	Approx. -26.6kPa	Approx. -26.6kPa
Max. pressure (in continuous use)	Approx. 98.0kPa	Approx. 29.4kPa	Approx. 29.4kPa
Max. EX-flow	Approx. 8L/10L/min	Approx. 3L/3.6L/min	Approx. 2.0L/min
Mounting	So as to set the motor shaft horizontal		
Ambient temperature	0°C to 40°C		
Connection port	Rc1/4		Rc1/8
Mass (approx.)	2.2kg		1.7kg
(Discrimination)	GA-380VF-DA	GA-330V	GS-3FD-F

## PERFORMANCE CURVE (at ambient temperature 20 )

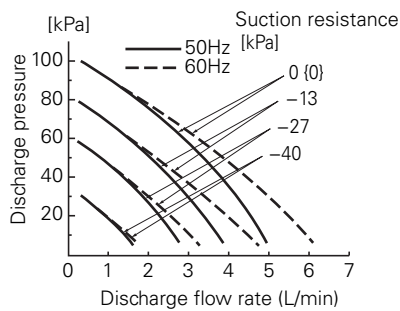

ZBG5

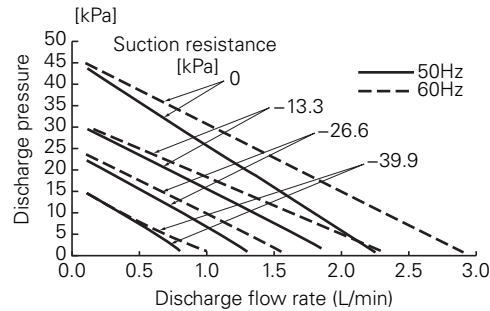

ZBG6



ZBG80

## OUTLINE ( Unit : mm )

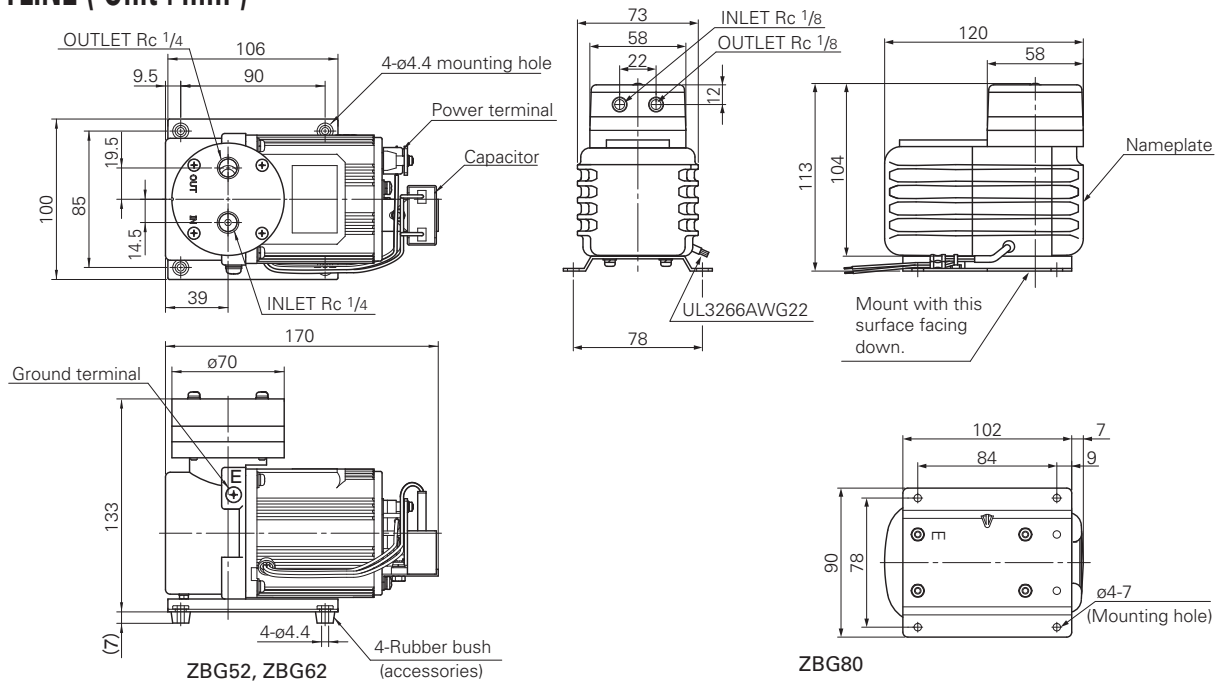

## SCOPE OF DELIVERY

### ZBG5, 6 main unit

Accessories:	Diaphragm	1
	Mounting tool	1
	Rubber foot	4

### ZBG main unit

Accessories:	Rubber foot	4
--------------	-------------	---

## Consumable parts/spare parts

For ZBG5	Diaphragm	ZBNG1012 (set of 5), Consumption: 1 to 2 pcs./year
For ZBG6	Valve	ZBNG1022 (set of 5), Consumption: 1 to 2 pcs./year

## Usage and caution in use

- 1) Since aspiration pressure of the aspirator is large, be sure to install a safety drain trap for draining process before the aspirator to prevent drain from being sucked up.
- 2) The diaphragm and the valve should be replaced periodically. Be sure to allow space for the replacement above the pump head. (Space sufficient for attachment/detachment of screws with a driver, 150mm or larger, is required.)

## Spare parts for 1 year (For ZBG5, ZBG6, and ZBG8)

ZBN3BG52: Diaphragm × 2, Valve × 1

# ■ DRAIN TRAP/POT/SEPARATOR (model: ZBH)

## SPECIFICATIONS

### 1. Safety Drain Trap

Model: ZBH51603  
 Suction sample gas flow rate: Max. 3L/min  
 Working pressure: -5.78kPa  
 Water sealing: 0.98kPa  
 Material: PVC (transparent)  
 Ambient temperature: 1°C to 40°C  
 Connection port size: Drain inlet ; Rc 1/4  
 Drain outlet; Rc 1/4  
 Mass: Approx. 0.6 kg

### 2. Drain Pot

Model; Length ZBH13□□03  
 255mm (ZBH130)  
 405mm (ZBH131)  
 650mm (ZBH133)

Material: PVC (transparent)  
 Ambient temperature: 1°C to 40°C

Connection port size:  
 Drain outlet; Rc 1/4  
 Inlet ; ø39

Mass: Approx. 0.8kg (ZBH130)

### 3. Sealed Drain Pot

Model: ZBH3<sup>0</sup><sub>1</sub>□□03

Working pressure:  
 1.0 MPa (material SUS)  
 0.1 MPa (material PVC)

Material: SUS304 or PVC (transparent)  
 Ambient temperature : 1°C to 40°C

Connection port size:  
 Rc 1/4

Internal volume: 280 cc for material SUS  
 370 cc for material PVC

Mass: Approx. 0.4kg (material PVC)  
 Approx. 1.5kg (material SUS)

### 4. Drain Separator

Model: ZBH81333 (1.1m dripping tube)  
 ZBH81533 (1.3m dripping tube)

Material: PVC (self-color)

Ambient temperature:  
 1°C to 40°C

Connection port size:  
 Gas inlet/outlet Rc 1/2  
 (with joint for ø10 Teflon tube)

Mass: Approx. 0.8kg

### 5. Bubbler

Model: ZBH65003  
 Gas outlet pressure:  
 Approx. +3.7kPa  
 Material: PVC (transparent)  
 Ambient temperature:  
 1°C to 40°C

Connection port size:  
 Gas inlet/outlet Rc 1/4  
 Drain inlet/outlet Rc 1/4

Mass: Approx. 0.6kg

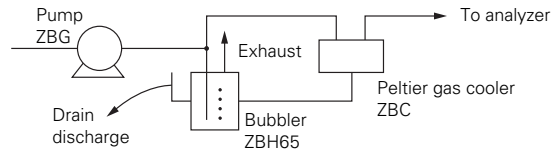

Usage of Bubbler

### 6. Tank

Model: ZBH41003  
 Internal volume: Approx. 1.5L  
 Material: PVC (non-transparent)  
 Ambient temperature:  
 1°C to 40°C

Connection port size:  
 Rc 1/4

Mass: Approx. 0.5kg

### 7. Gas Conditioner

Model: ZBH91003  
 Sample gas pressure:  
 Approx. -3kPa to +3kPa

Outlet gas pressure:  
 Approx. +4.5kPa

Materials:  
 Main unit; PVC (transparent)  
 Filter; Polyethylene  
 O-ring; Chloroprene

Pore size of filter: Approx. 5µm

Ambient temperature:  
 1°C to 40°C

Connection port size:  
 Sample gas inlet ; Rc 3/8  
 Gas inlet/sample gas outlet ; ø6.5mm  
 Drain outlet ; Rc 3/8  
 Drain inlet ; Rc 1/4

Mass: Approx. 1.5kg

## CODE SYMBOLS (ZBH)

1 2 3 4 5 6 7 8							
Z	B	H					3
Description							
Part name		Application/specification					
1	3	0	0	.....	Drain pot	Length 255mm	
1	3	1	0	.....		Length 405mm	
1	3	3	0	.....		Length 650mm	
1	3	9	0	.....		Length as specified	
3	0	0	0	.....	Sealed drain pot	Material SUS 304, length L = 120mm	
3	0	9	0	.....		Material SUS 304, length L = as specified (within 1m)	
3	1	0	0	.....		Material PVC, length L = 200 mm	
3	1	9	0	.....		Material PVC, length L = as specified (within 1m)	
3	5	0	0	.....	Demister	Drain separation, PVC	
4	1	0	0	.....	Tank	Buffer tank for paramagnetic oxygen analyzer	
5	1	6	0	.....	Safety drain trap	Length X = 590mm, Y = 120mm	
5	1	9	0	.....		Length X, Y specifiable (X + Y within 800mm)	
6	5	0	0	.....	Bubbler	Length L = 400mm	
6	5	9	0	.....		Length L, specifiable	
8	1	3	3	.....	Drain separator	With 1.1 m dripping tube (with joint for ø10mm tube)	
8	1	5	3	.....		With 1.3 m dripping tube (with joint for ø10mm tube)	
9	1	0	0	.....	Gas conditioner	Mist filter, safety drain trap and bubbler combined into integral body	

## CONSUMABLE AND SPARE PARTS

- Filter element for ZBH9  
 ZBNH2012 (2pcs/1set)
- O-ring for ZBH9  
 ZBNN1012 (10pcs/1set) JIS G65
- Spare parts for 1 year for ZBH9  
 ZBN3BB42  
 Filter × 3, O-ring × 2



# OUTLINE ( Unit : mm )

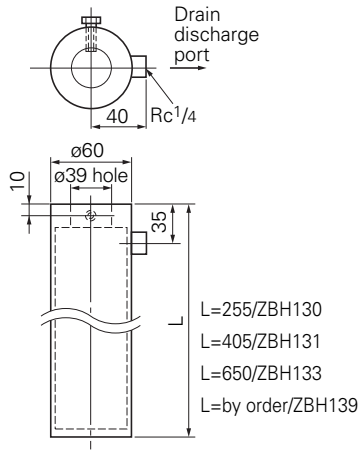

**Drain pot  
(ZBH13□)**

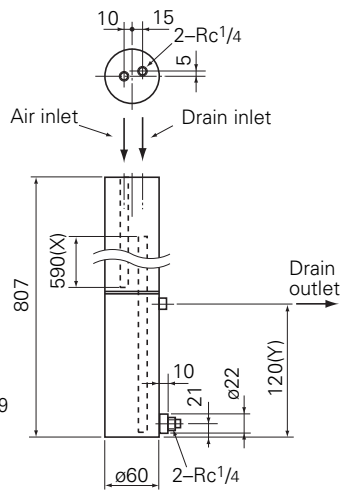

**Safety drain trap  
(ZBH51)**

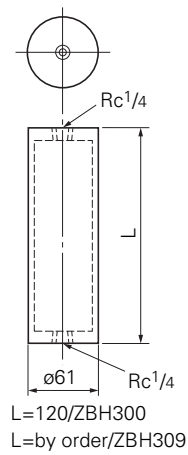

L=120/ZBH300  
L=by order/ZBH309

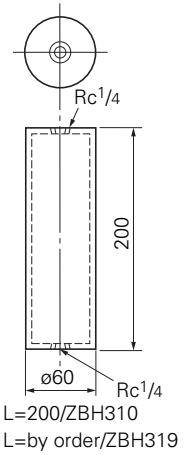

L=200/ZBH310  
L=by order/ZBH319

**Sealed drain pot  
(ZBH30)**

**(ZBH31)**

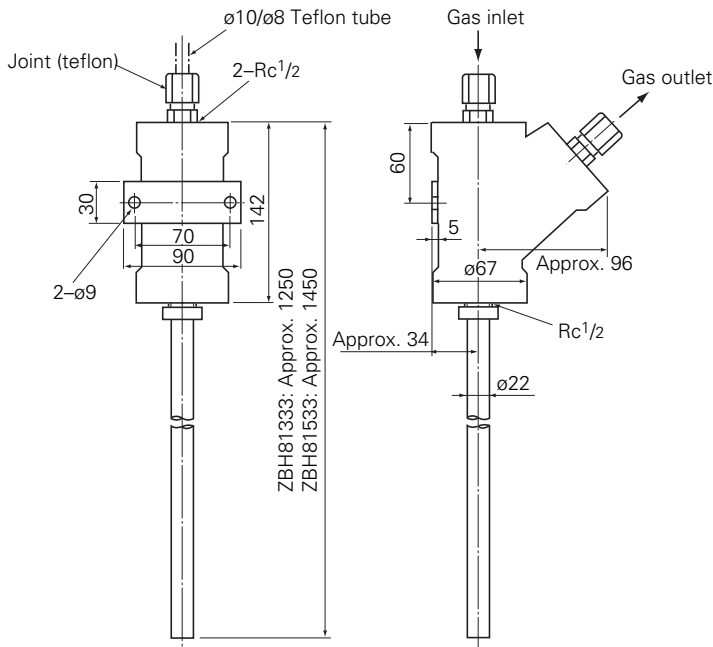

**Drain separator (ZBH81)**

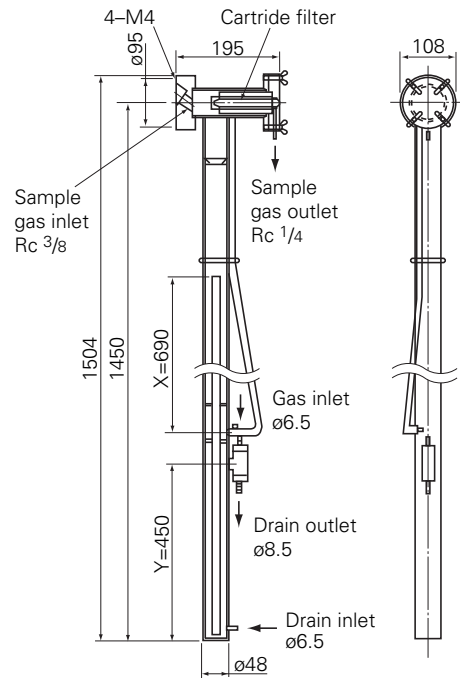

**Gas conditioner (ZBH91)**

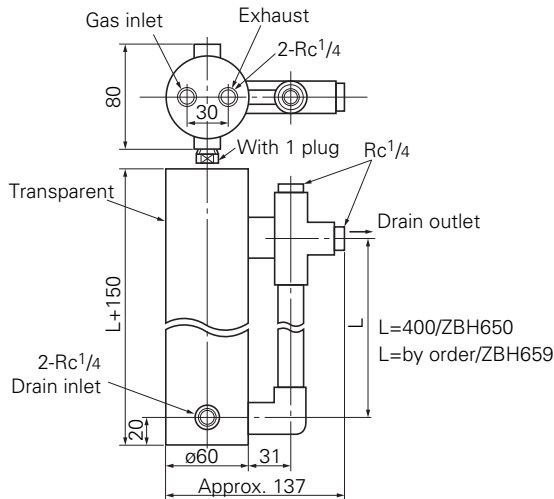

**Bubbler (ZBH65)**

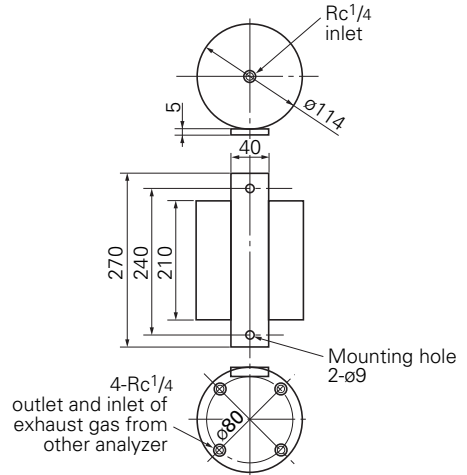

**Tank (ZBH41)**

# ■ GAS CONVERTER (model: ZDL)

## SPECIFICATIONS

### 1. NO<sub>2</sub>/NO CONVERTER

Type	ZDL03001	ZDL05001
Mounting	Indoor surface mounting	
Target gas	Exhaust gas from general boilers/ atmosphere (Contact us for applications to gases other than those.)	
Catalyst	Usage: 2cm <sup>3</sup> Replacement cycle: About 12 months (When O <sub>2</sub> concentration reaches 5%, NO <sub>2</sub> concentration 10ppm and flow rate 0.3L/min.) Temperature setting: 220±10°C (Detection terminal: K thermocouple)	
Temperature controller	Built in Microcontroller X (Type: PXR4)	Built in Microcontroller X (Type: PXE4)
Material of part contacting gas	Ceramic, Viton, glass wool, SUS316	
Exchange efficiency	95% or higher, Conforming to JIS	
Gas flow rate	0.5L/min	
Ambient temperature	-5°C to +45°C	
Power supply	100V AC, 50/60Hz	100 to 240V AC, 50/60Hz
Power consumption	Approx. 85VA	
Mass (approx.)	1.1kg	1.2kg
Gas condition	Gases with dust and drain removed at 150°C or lower	
Overseas use		CE mark compliant
Contact output		Temperature alarm · Contact is closed during normal operation · Contact is opened when the temperature is outside the range of ±20°C of a temperature setpoint.

### 2. CO/CO<sub>2</sub> CONVERTER

Type	ZDL23001	ZDL25001
Mounting	Indoor surface mounting	
Target gas	Atmosphere (Contact us for applications for other gases.)	
Catalyst	Usage: 3cm <sup>3</sup> Replacement cycle: About 6 months (Varies depending on usage conditions.) Temperature setting: 220±20°C (Detection terminal: K thermocouple)	
Temperature controller	To be installed separately Microcontroller X (Type: PXR4)	To be installed separately Microcontroller X (Type: PXE4)
Material of part contacting gas	Ceramic, Viton, glass wool, SUS316	
Exchange efficiency	99% or higher (100ppm CO or lower) (Standard: 99.9%)	
Gas flow rate	Standard: 0.5L/min. or 1L/min.	
Ambient temperature	-5°C to +45°C	
Power supply	100V AC, 50/60Hz	100 to 240V AC, 50/60Hz
Power consumption	Approx. 85VA	
Mass	Approx. 1.1kg	Approx. 1.2kg
Gas condition	Gases with dust and drain removed at 150°C or lower	
Overseas use		CE mark compliant
Contact output		Temperature alarm · Contact is closed during normal operation · Contact is opened when the temperature is outside the range of ±20°C of a temperature setpoint.

## STANDARD ACCESSORIES

Converter type	ZDL03	ZDL23
	ZDL05	ZDL25
CO/CO <sub>2</sub> catalyst (for 1 cycle)	—	1
Glass wool	—	1

## SPARE PARTS FOR 1-YEAR OPERATION

Spare part model	ZBN1DL72	ZBN1DL82	ZBN1DL2
Converter type	ZDL03	ZDL05	ZDL23 ZDL25
NO <sub>2</sub> /NO catalyst	1	2	
CO/CO <sub>2</sub> catalyst			1
Glass wool	1	2	1
Joint	2	4	2

# OUTLINE ( Unit : mm )

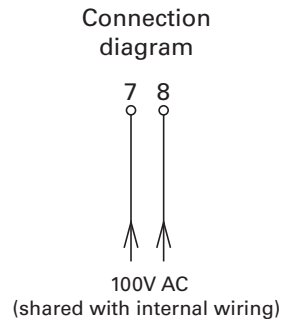
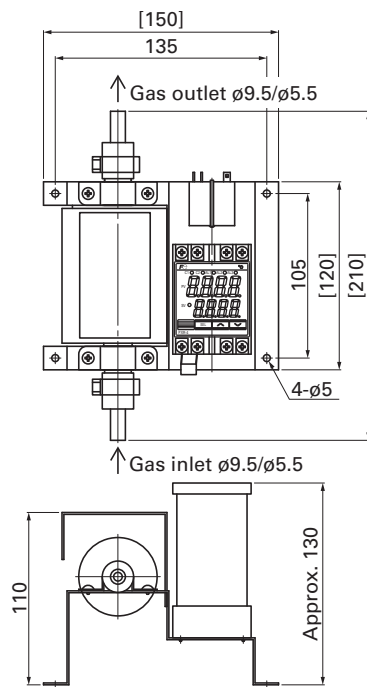

NO<sub>2</sub>/NO converter  
ZDL03001  
CO/CO<sub>2</sub> converter  
ZDL23001

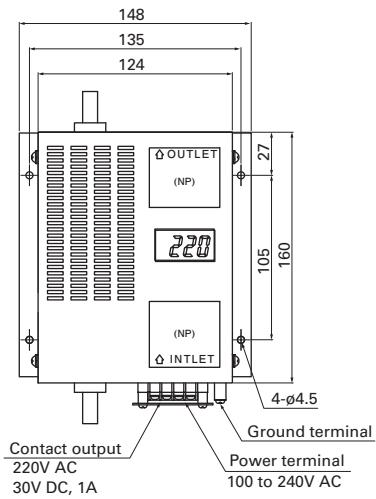

Front view

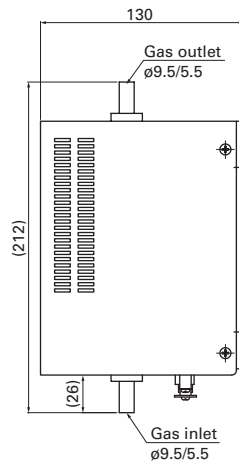

Right side view

Connection diagram

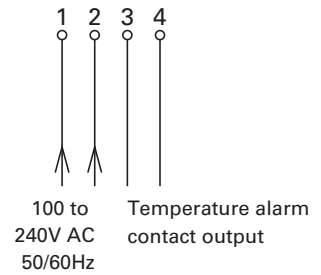

NO<sub>2</sub>/NO converter  
ZDL05001  
CO/CO<sub>2</sub> converter  
ZDL25001

# STANDARD GAS (model: ZBM)

## CODE SYMBOLS

### 1. Pure Gas in volume of 3.4 or 10Lcylinder

1	2	3	4	5	6	7	8	9	10	Description	
Z	B	M		Y	0	4	-			Cylinder size	
1										10L	
3										3.4L	
										Component and application	
A	Y	0	4	-	0					CO <sub>2</sub>	
B	Y	0	4	-	0					CO	
E	Y	0	4	-	0					CH <sub>4</sub>	
K	Y	0	4	-	0					H <sub>2</sub>	
L	Y	0	4	-	0					Ar	
M	Y	0	4	-	0					He	
P	Y	0	4	-	0					NH <sub>3</sub>	
S	Y	0	4	-	0					O <sub>2</sub>	
N	Y	0	4	-	0					N <sub>2</sub> (B) For general use	
T	Y	0	4	-	0					N <sub>2</sub> (A) Equivalent to zero gas for generation source with certification	
T	Y	0	4	-	4					N <sub>2</sub> (A) Zero gas for generation source with certification	
R	Y	0	4	-	0					AIR (B) For general use	
V	Y	0	4	-	0					AIR (A) Equivalent to zero gas for generation source with certification	
V	Y	0	4	-	4					AIR (A) Zero gas for generation source with certification	
Z	Y	0	4	-	0					Others	
										Connection thread	Export certificate
1										Right-hand thread	None
2										Left-hand thread	None
3										Right-hand thread	Provided
4										Left-hand thread	Provided

### 3. Pure Gas in volume of 47Lcylinder

1	2	3	4	5	6	7	8	9	10	Description	
Z	B	M	2	Y	0	4	-			Description	
										O <sub>2</sub>	
										N <sub>2</sub> (B) For general use	
										N <sub>2</sub> (A) Equivalent to zero gas for generation source with certification	
										N <sub>2</sub> (A) Zero gas for generation source with certification	
										AIR (B) For general use	
										AIR (A) Equivalent to zero gas for generation source with certification	
										AIR (A) Zero gas for generation source with certification	
										Others	
										Connection thread	Export certificate
1										Right-hand thread	None
2										Left-hand thread	None
3										Right-hand thread	Provided
4										Left-hand thread	Provided

## OUTLINE ( Unit : mm )

Internal volume	øD, L	øD	L	Approx. weight [kg]
10L	140 965	140	965	15
3.4L	140 425	140	425	6

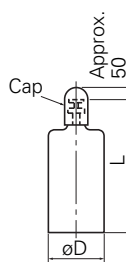

Note1) Two-component mixed gas (3.4, 10L), Deviation  
 Gas with class 1 certification :1% of labeled value  
 Others :2%  
 Valid term :1 year

### 2. 2-Component Mixture Gas in volume of 3.4 or 10Lcylinder

1	2	3	4	5	6	7	8	9	10	Description	
Z	B	M		N		4	-			Cylinder size	
1										10L	
3										3.4L	
										Gas component and residual gas	
A										CO <sub>2</sub>	N <sub>2</sub>
B										CO	N <sub>2</sub>
E										CH <sub>4</sub>	N <sub>2</sub>
K										H <sub>2</sub>	N <sub>2</sub>
L										Ar	N <sub>2</sub>
M										He	N <sub>2</sub>
P										NH <sub>3</sub>	N <sub>2</sub>
S										O <sub>2</sub>	N <sub>2</sub>
T										SO <sub>2</sub>	N <sub>2</sub>
U										NO	N <sub>2</sub>
Z										Other	N <sub>2</sub>
										Concentration	
A										45 to 50ppm	
B										90 to 100ppm	
C										180 to 200ppm	
D										225 to 250ppm	
E										450 to 500ppm	
F										900 to 1000ppm	
G										1800 to 2000ppm	
H										0.45% to 0.5%	
J										0.9% to 1%	
K										1.8% to 2%	
L										4.5% to 5%	
M										9% to 10%	
N										18% to 20%	
P										45% to 50%	
Z										Other as specified	
										With/without of specification	
0										None	
1										Approved class 1 standard gas for general use	
2										Approved class 2 standard gas for general use	
										Connection thread	Export certificate
1										Right-hand thread	None
2										Left-hand thread	None
3										Right-hand thread	Provided
4										Left-hand thread	Provided

### 4. Canned Standard Gas in volume of 0.7Lcylinder

1	2	3	4	5	6	7	8	9	10	Description	
Z	B	M	4					4	-	0	0
										Component and concentration	
										N <sub>2</sub> (B)	
										CO <sub>2</sub> 1800 to 2000ppm/N <sub>2</sub>	
										Specified component/concentration (Contact Fuji.)	

Note) Canned standard gas is available in dozen (12).

Note2) Thread for connection (22/14 thread):  
 Left-hand screw :Included 5% more combustible gas (except NH<sub>3</sub>)  
 Right-hand screw :Other gases

## ⚠ Caution on Safety

\*Before using this product, be sure to read its instruction manual.



Global Sales Section  
 Instrumentation & Sensors Planning Dept.  
 1, Fuji-machi, Hino-city, Tokyo 191-8502, Japan  
<http://www.fujielectric.com>  
 Phone: +81-42-514-8930 Fax: +81-42-583-8275  
<http://www.fujielectric.com/products/instruments/>